

Gamma3[®]

Hip Fracture Nailing System



Operative technique



Gamma3

Hip Fracture Nailing System

Contents

| | | | |
|--|-----------|---|-----------|
| 1. Introduction | 3 | U-blade lag screw | 40 |
| 2. Indications and contraindications | 4 | U-blade lag screw insertion and placement | 40 |
| 3. MRI safety information | 6 | U-blade insertion | 41 |
| 4. Implant and instrument design | 7 | End cap insertion | 42 |
| 5. Operative technique | 13 | Set screw insertion | 43 |
| Pre-operative planning | 14 | Set screw fixation | 44 |
| Patient positioning & fracture reduction | 15 | Distal targeting system | 46 |
| Special reduction techniques | 16 | Distal locking options | 46 |
| Incision | 18 | Pre-op functional check and assembly | 46 |
| Entry point & opening | 20 | A-P adjustment | 48 |
| Preparation of medullary canal | 22 | Distal locking | 49 |
| Long nail length | 25 | C-arm positioning | 50 |
| Assembly of proximal target device and implant | 26 | C-arm adjustment | 51 |
| Nail insertion | 29 | Sleeve adjustment | 52 |
| Final seating of nail | 29 | Drilling and locking | 52 |
| Implant positioning | 30 | Disassembly | 55 |
| Implant positioning with one shot device | 31 | Distal screw locking | 56 |
| K-wire placement | 32 | Trochanteric nails | 56 |
| Fragment control clip | 34 | Long nails | 58 |
| Assembly and insertion of sleeve | 34 | Free hand technique | 58 |
| K-wire placement | 35 | End cap insertion | 60 |
| Removal of clip | 35 | Post-operative care and rehabilitation | 61 |
| Lag screw insertion and placement | 36 | Extraction | 62 |
| Lag screw fixation | 39 | Extraction of the u-blade lag screw | 63 |
| Compression/apposition | 39 | Alternative u-blade extraction | 64 |

This publication sets forth detailed recommended procedures for using Stryker devices and instruments. It offers guidance that you should heed, but, as with any such technical guide, each surgeon must consider the particular needs of each patient and make appropriate adjustments when and as required.

A workshop training is recommended prior to performing your first surgery.

Follow the instructions provided in our cleaning and sterilization guide (OT-RG-1). All non-sterile devices must be cleaned and sterilized before use. Multicomponent instruments must be disassembled for cleaning. Please refer to the corresponding assembly/ disassembly instructions.

Please remember that the compatibility of different product systems has not been tested unless specified otherwise in the product labeling. Consult Instructions for Use (www.stryker.com) for a complete list of potential adverse effects, contraindications, warnings and precautions. The surgeon must discuss all relevant risks including the finite lifetime of the device with the patient when necessary.

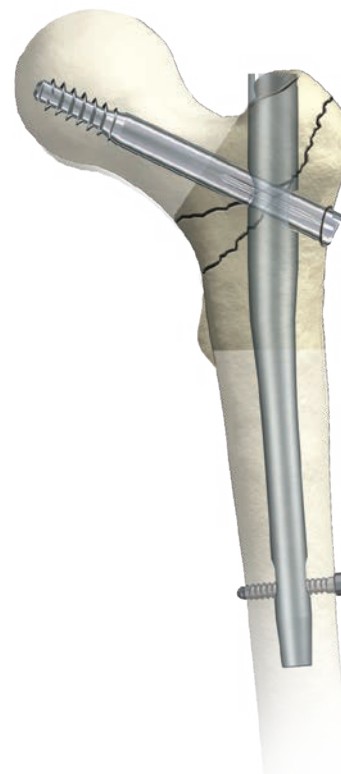

Introduction

The Gamma3 intramedullary nails feature a variety of neck-shaft angles (CCD* angle), distal diameters, lengths and distal locking configurations (trochanteric nails and long nail, refer to sections '2.1. Trochanteric Nail' and '2.2. Long Nail') in order to accommodate anatomical variations in the femur. The nails are designed to be fixated by lag screws (standard lag screw or u-blade lag screw, refer to section '2.3. Screws and accessories') in the femoral head and by locking screws in the diaphysis. The set screw is designed to control rotation and dynamization of the proximal fragment. The end cap is designed for proximal closure of the nail to prevent bone ingrowth. For a general design and component overview of a Gamma3 Nail, refer to Fig. 1.

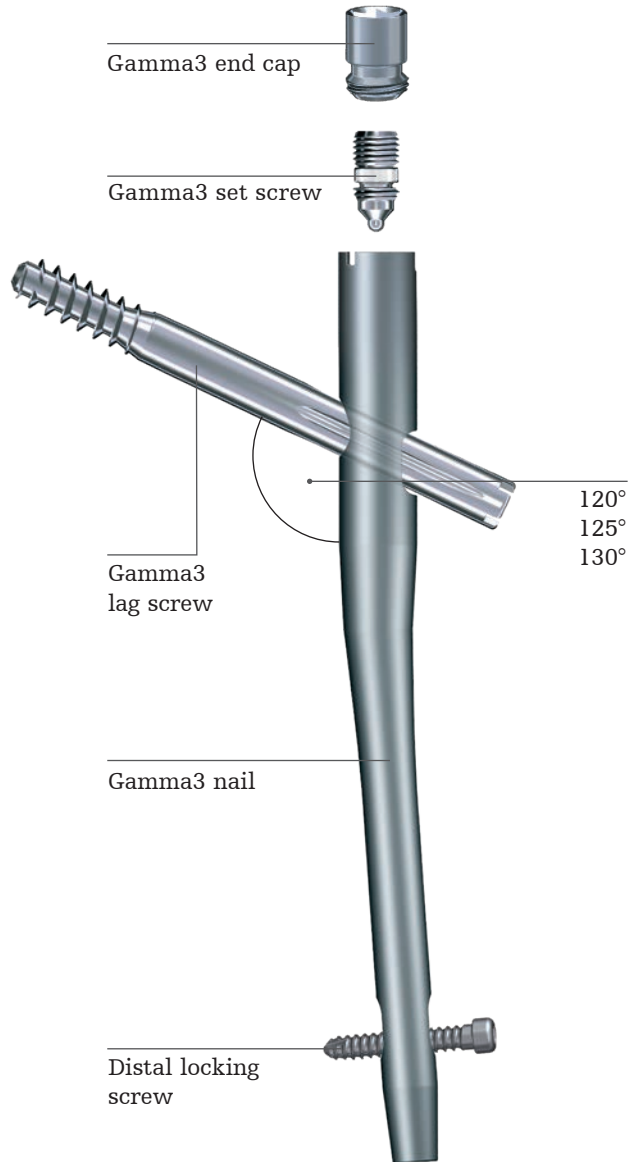

Fig. 1

*CCD: Center Column Diaphysis

Indications and contraindications

Intended Use

The Gamma3 System is intended to achieve functionally stable osteosyntheses and stabilization of bones and bone fragments.

Indications

The Gamma3 System is indicated for the treatment of stable and unstable fractures as well as for stabilization of bones and correction of bone deformities in the intracapsular, trochanteric, subtrochanteric and shaft regions of the femur (including osteoporotic and osteopenic bone). The u-blade lag screw is also indicated for rotationally unstable fractures.

Contraindications

The physician's education, training and professional judgment must be relied upon to choose the most appropriate device and treatment. Conditions presenting an increased risk of failure include:

- Any active or suspected latent infection or marked local inflammation in or about the affected area.
- Compromised vascularity that would inhibit adequate blood supply to the fracture or the operative site.
- Bone stock compromised by disease, infection or prior implantation that can not provide adequate support and/or fixation of the devices.
- Material sensitivity, documented or suspected.
- Obesity. An overweight or obese patient can produce loads on the implant that can lead to failure of the fixation of the device or to failure of the device itself.
- Patients having inadequate tissue coverage over the operative site.
- Implant utilization that would interfere with anatomical structures or physiological performance.
- Any mental or neuromuscular disorder which would create an unacceptable risk of fixation failure or complications in postoperative care.
- Other medical or surgical conditions which would preclude the potential benefit of surgery.

Warnings and precautions

This operative technique has been devised in consultation with leading surgeons in many countries to be a basic guide, particularly for less experienced users of the Gamma3 System. It is acknowledged that several alternative approaches to certain elements of the procedure are available, and may have advantages for particular situations or surgeons.

WARNING

Internal fixation of medial neck fractures is associated with high complication rates, but a successful treatment may preserve the patient's hip joint. The surgeon must use his or her own professional clinical judgment to thoroughly evaluate the potential advantages, disadvantages and all risks associated with the use of the Gamma3 System in medial neck fractures, and discuss them with the patient, when necessary.

The u-blade lag screw is indicated for rotationally unstable fractures.

WARNING

The Gamma3 Nail is designed for temporary implantation until bone consolidation occurs. Therefore if no bone consolidation occurs or if consolidation is not sufficient, the system may break. The aim of post-operative care must be to ensure the promotion of bone consolidation. The Gamma3 Nail is not intended for full weight bearing in patients with complex unstable fractures until sufficient bone consolidation is confirmed in the follow up X-rays.

Long nails may provide higher stability due to longer distance between locking configuration and fracture line; especially important for subtrochanteric fractures and shaft fractures.

CAUTION

The coupling of elastosil handles contains a mechanism with one or multiple ball bearings. In case of applied axial stress on the elastosil handle, those components are pressed into the surrounding cylinder resulting in a complete blockage of the device and possible bending.

To avoid intra-operative complications and secure long-term functionality, we mandate that elastosil handles be used only for their intended use. Do not hit any elastosil handles.

CAUTION

Care should be taken to utilize the cleaning stylet for intra and post-operative cleaning of cannulated instruments. Rinsing with saline solution may help prevent accumulation of debris.

WARNING

Fixation screws:

Stryker bone screws are not approved or intended for screw attachment or fixation to the posterior elements (pedicles) of the cervical, thoracic or lumbar spine.

MRI safety information

MRI safety information (Ti):

Non-clinical testing has demonstrated the Gamma3 Titanium Nailing System is MR Conditional. A patient with this device can be safely scanned in an MR system meeting the following conditions:

- Static magnetic field of 1.5 T or 3.0 T
- Maximum spatial field gradient of 3000 gauss/cm (30 T/m)
- Maximum MR system reported, whole body averaged specific absorption rate (SAR) of 2 W/kg (Normal Operating Mode)
- Scan time restriction: maximum 15 minutes of continuous RF (a sequence or back to back series/scan without breaks) followed by a wait time of 15 minutes if this limit is reached.

Under the scan conditions defined above, the Gamma3 Titanium Nailing System is expected to produce a maximum temperature rise of less than 6.9 °C after 15 minutes of continuous scanning.

In non-clinical testing, the image artifact caused by the device extends approximately 28mm from the Gamma3 Titanium Nailing System when imaged with a gradient echo pulse sequence and a 1.5 T MRI system.

CAUTION

The MRI safety information provided is based on testing which did not include supplementary devices. If there are supplementary devices (i.e. plates, screws, wires, etc.) present in proximity to the Gamma3 Titanium Nailing System, this could result in additional MRI effects and the information provided above may not apply.

MRI Safety Information (StSt):

Non-clinical testing has demonstrated the Gamma3 Stainless Steel Nailing System is MR Conditional. A patient with this device can be safely scanned in an MR system meeting the following conditions:

- Static magnetic field of 1.5 T or 3.0 T
- Maximum spatial field gradient of 2000 gauss/cm (20 T/m)
- Maximum MR system reported, whole body averaged specific absorption rate (SAR) of 2 W/kg (Normal Operating Mode)
- Scan time restriction: maximum 15 minutes of continuous RF (a sequence or back to back series/scan without breaks) followed by a wait time of 15 minutes if this limit is reached.

Under the scan conditions defined above, the Gamma3 Stainless Steel Nailing System is expected to produce a maximum temperature rise of less than 6.9 °C after 15 minutes of continuous scanning.

In non-clinical testing, the image artifact caused by the device extends approximately 79 mm from the Gamma3 Stainless Steel Nailing System when imaged with a gradient echo pulse sequence and a 1.5 T MRI system.

CAUTION

The MRI safety information provided is based on testing which did not include supplementary devices. If there are supplementary devices (i.e. plates, screws, wires, etc.) present in proximity to the Gamma3 Stainless Steel Nailing System, this could result in additional MRI effects and the information provided above may not apply.

Implant and instrument design

2.1. Trochanteric Nail

The Gamma3 Trochanteric Nails are available in three different lengths: 170mm, 180mm and 200mm. The anatomical shape of all trochanteric nails is universal. For design specifications, refer to Fig. 2. Trochanteric nails are straight.

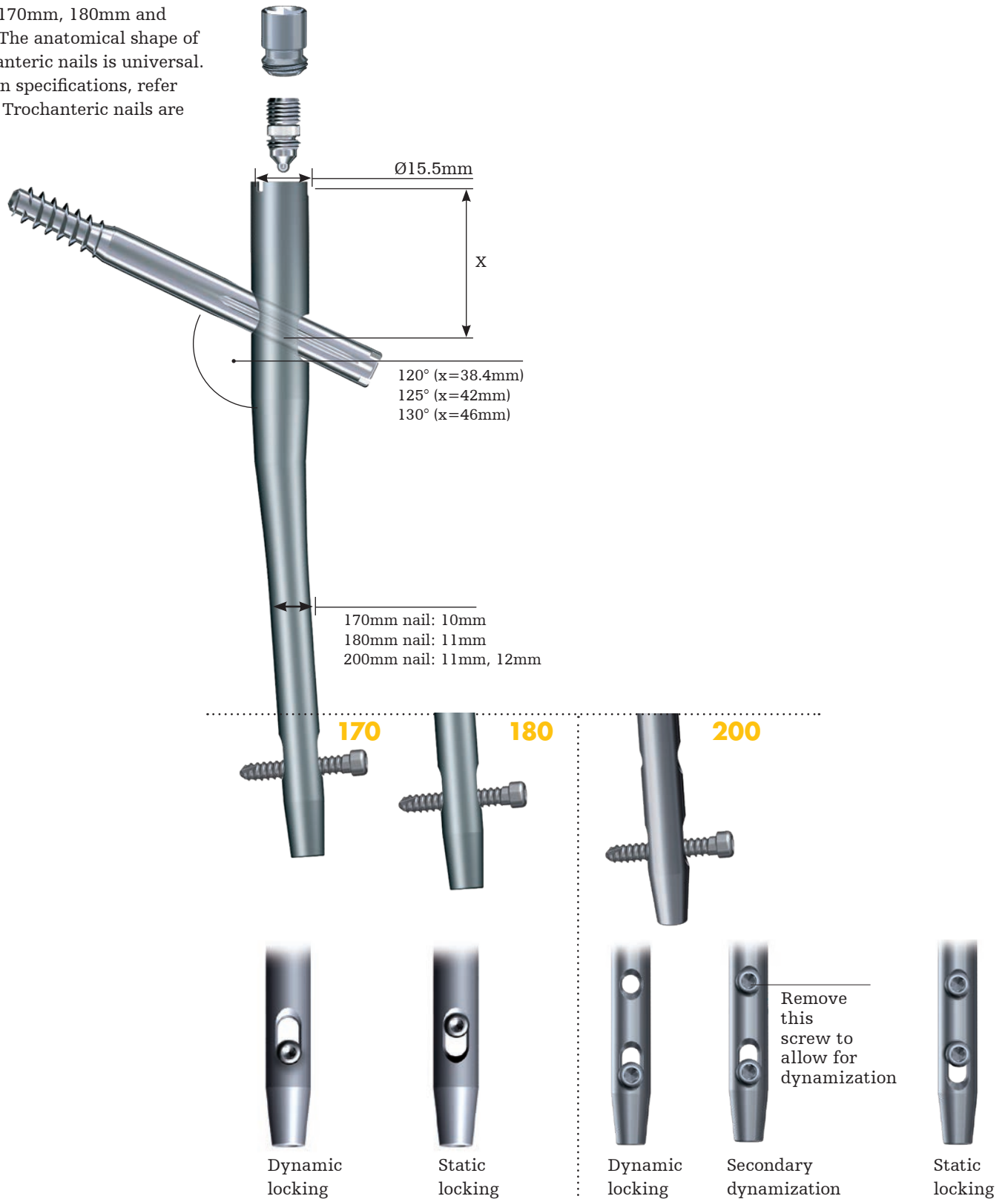

Fig. 2

Implant and instrument design

2.2. Long Nail

The Gamma3 Long Nail is available in different radii of curvature (R=1.5m, R=2.0m) and lengths (240mm to 480mm in 20mm increments). All nail types come in left and right versions. Refer to Fig. 3. The anteversion angle is 10 degrees.

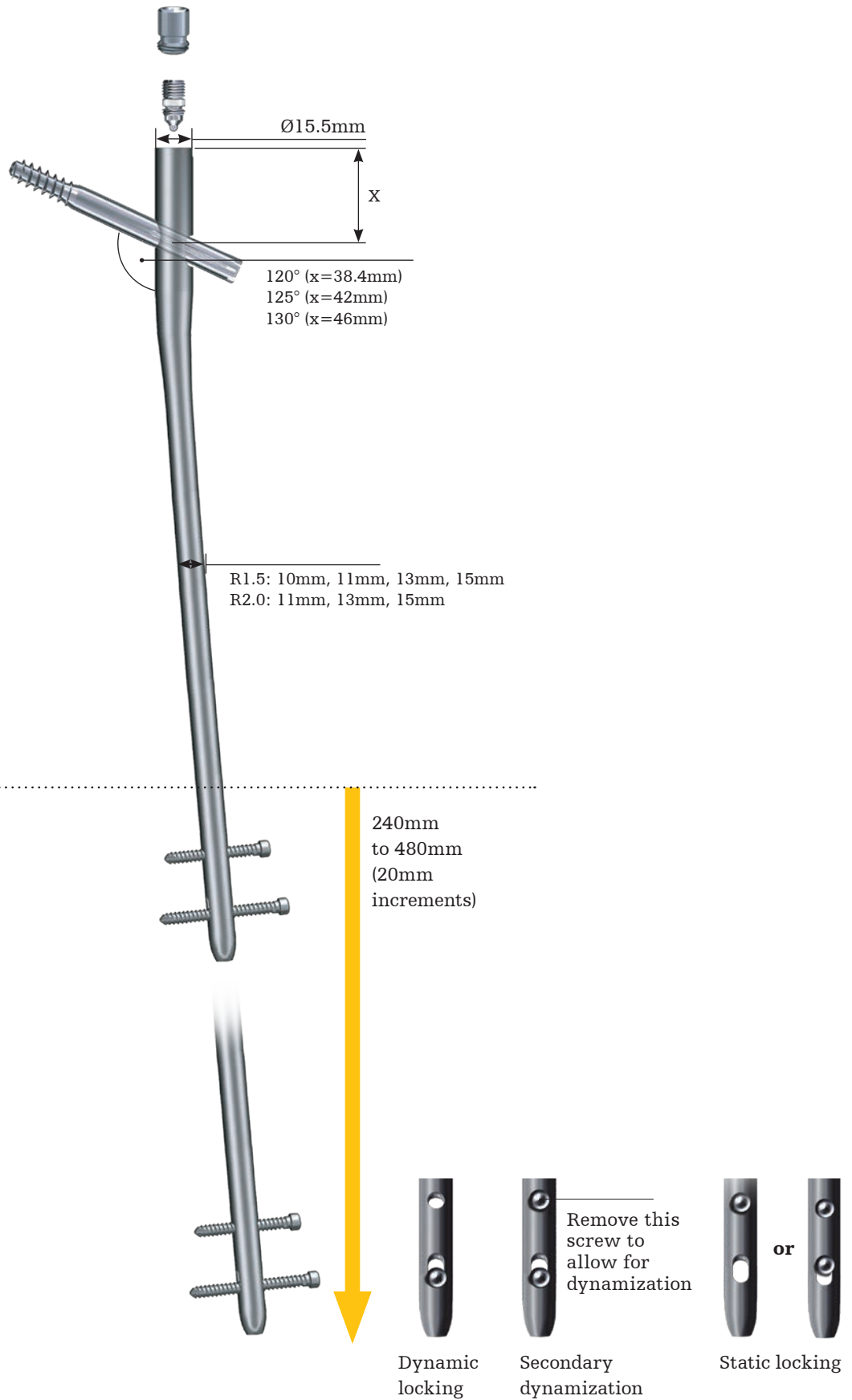

Fig. 3

Implant and instrument design

2.3. Screws and accessories

Lag Screw

The lag screw is available in two different types: Gamma3 Lag Screw (Fig. 4) and Gamma3 U-Blade Lag Screw (Fig. 5a and 5b). Both are available in lengths from 70 to 130mm in 5mm increments. The diameter of all lag screws is 10.5mm. The Gamma3 U-Blade Lag Screw is designed to provide additional rotational stability and fixation performance*.

Gamma3 Lag Screw

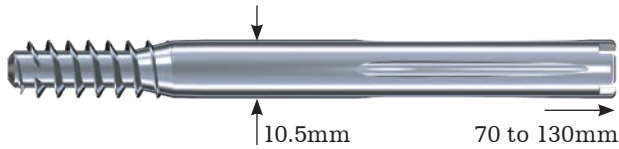

Fig. 4

Gamma3 U-blade Lag Screw

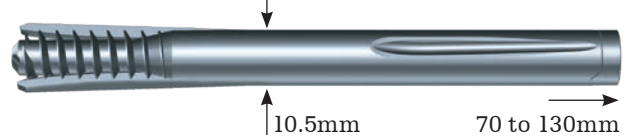

Fig. 5a

The Gamma3 U-Blade Lag Screw consists of three different parts: u-blade lag screw, u-blade and end cap (Fig. 5b).



Gamma3 U-Blade Lag Screw



Gamma3 U-Blade



End cap

Fig. 5b

When the u-blade is assembled to the u-blade lag screw, the width of the tip is increased to 12.5mm due to the spread of the u-blade (Fig. 5c).

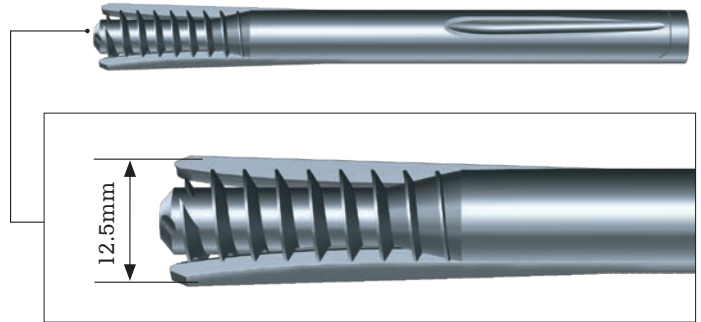

Fig. 5c

*Born et al. Hip Screw Migration Testing: First Results for Hip Screws and Helical Blades utilizing a newoscillating Test Method. J Orthop Res. 2011 May;29(5):760-6.

Implant and instrument design

Set screw

The self-retaining set screw (Fig. 6a) is inserted into the proximal part of the nail in order to control rotation and dynamization of the lag screw. Refer to Fig. 6b.



Fig. 6a

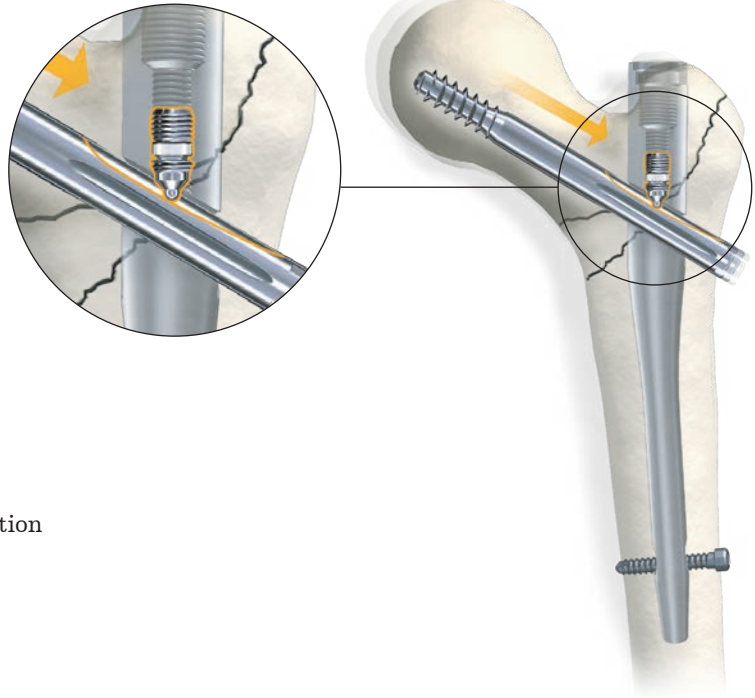

Fig. 6b

The set screw mechanism allows for lateral dynamization of the lag screw while preventing medial movement.

One set screw is packed in each Gamma3 Nail Kit package (Fig. 7).



Fig. 7

Implant and instrument design

Locking screw

The locking screw is used to control rotational and axial fixation of the nail. It is available in lengths from 25 to 120mm in 5mm increments. Additionally, 2.5mm increments are available from 25 to 60mm. For all locking screws, the thread diameter is 5mm. Refer to Fig. 8.

The Ø5mm locking screws of the IMN Screws System are also compatible with the Gamma3 Titanium Nailing System. The Advanced Locking screws are not compatible.

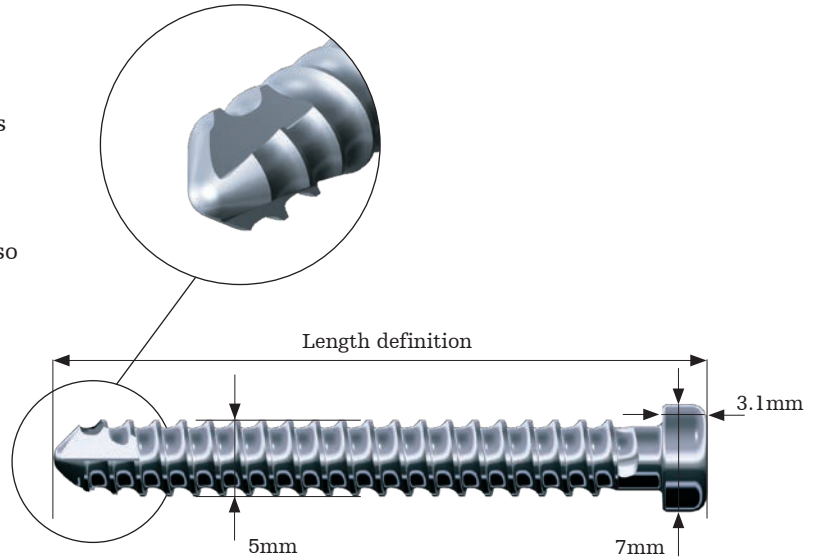

Fig. 8

End cap

The end cap is designed for proximal closure of the nail to prevent bony ingrowth. It is available in three different sizes: 0mm, 5mm, 10mm. Refer to Fig. 9.



Fig. 9

Fragment control clip

The fragment control clip (Fig. 10) is designed to stabilize rotationally unstable femoral head-neck fragments during preparation of the lag screw canal and insertion of the lag screw.

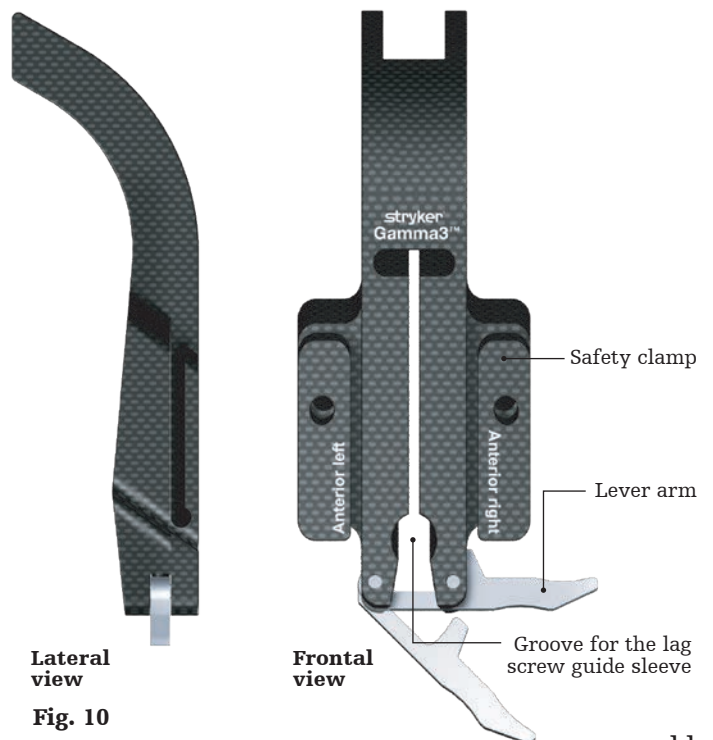

Lateral view
Fig. 10

Implant and instrument design

Distal targeting system

The distal targeting system (Fig. 11) is used to lock long nails, as opposed to the traditional method of freehand locking. Long nails adapt to the anatomical shape of the femur. The distal targeting system allows for adjustment of the A-P sleeve position enabling guided locking.

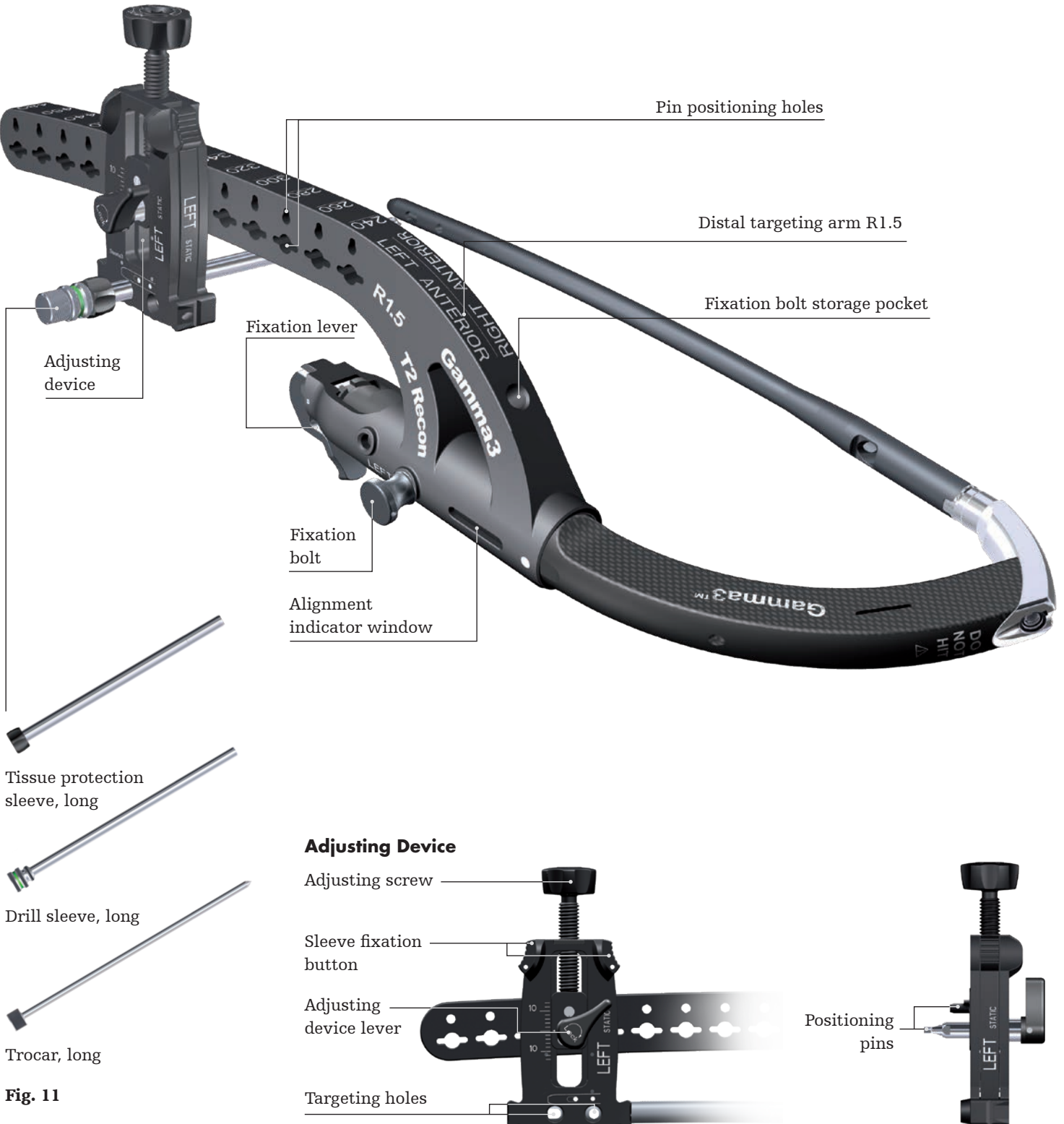

Fig. 11

Operative technique

Operative technique

Pre-operative planning

X-ray templates may be used during pre-operative planning to select the correct implant and the optimal nail angle. These templates show the true implant size at a magnification of 15% in anterior-posterior frontal view (Fig. 12, Fig. 13, Fig. 14, Fig. 15).

The X-rays should be taken at this magnification (15 %) for an optimal surgical outcome. If accurate anatomical reduction has been achieved, the X-ray can be taken from the fractured hip or from the contralateral side. An accurate neck-shaft angle can only be measured if the X-ray projection is adapted to the anatomical anteversion. This projection can be achieved by adjusting the X-ray beam 90° off a true lateral picture*. Alternatively the femoral neck angle, i. e. the angle between the femoral shaft mid-axis and the femoral neck mid-axis, could be measured using a goniometer.

In case the X-ray templates do not show an anatomical fit with the bone, a different implant solution should be considered.

⚠ WARNING

Please ensure precise alignment of the affected hip joint when using these templates. Template magnification is 15 %. All dimensions (nail angle and implant sizing) resulting from using these templates must be verified intra-operatively to ensure proper implant selection.

Stryker Imaging offers also the Advanced Case Plan including digital template for Gamma3 System as an alternative.

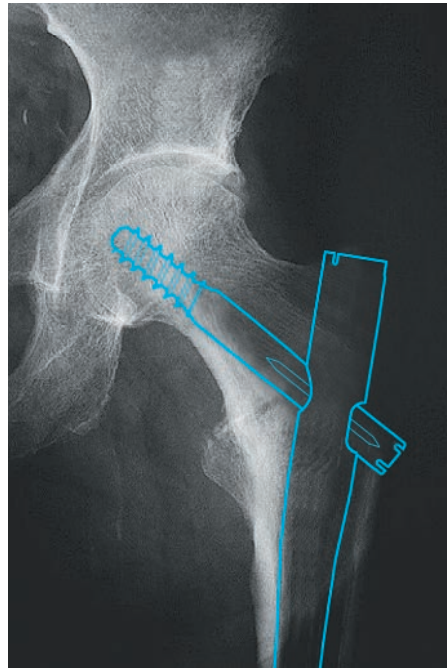

Fig. 12

X-ray in a/p view, showing implant template

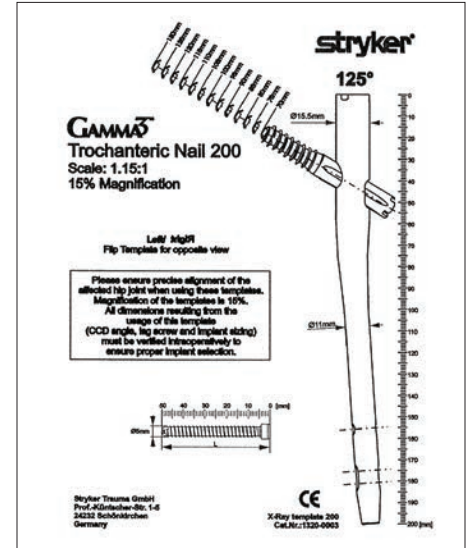

Fig. 13

Gamma3 Trochanteric Nail 200 X-ray template, (Ref. No. 1320-0003)

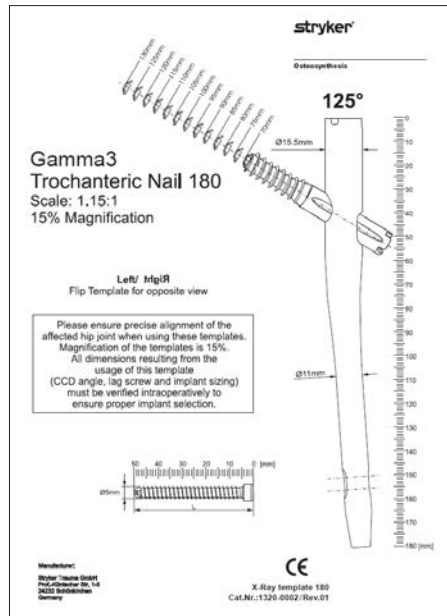

Fig. 14

Gamma3 Trochanteric Nail 180 X-ray template, (Ref. No. 1320-0002)

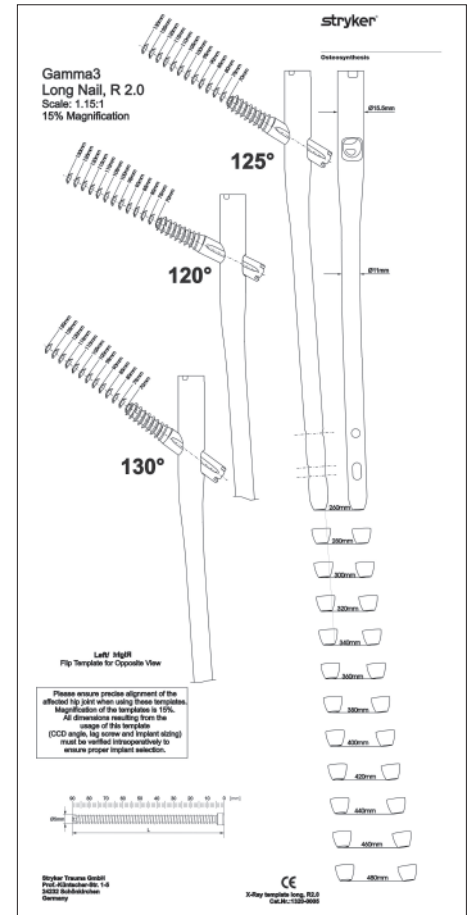

Fig. 15

Gamma3 Long Nail R2.0 X-ray template, (Ref. No. 1320-0005)

*True lateral picture: Femoral neck axis is parallel to proximal diaphysis

Operative technique

⚠ CAUTION

Prior to nail insertion, the implant and instrument assembly must be checked. Ensure that the sleeve angle matches the corresponding nail angle chosen, e.g. a 125° position in speedlock sleeve for a 125° nail, and the distal sleeve matches either for “dynamic” or “static” locking as required.

Patient positioning

The patient is typically placed in a supine position on the fracture table (refer to Fig. 16) and closed reduction of the fracture is recommended. Reduction should be achieved as anatomically as possible. If this is not achievable in a closed procedure, open reduction may be necessary.

Position the image intensifier as illustrated in Fig. 17 in order to easily obtain both, anterior-posterior (A-P) and mediolateral (M-L) projections of the affected trochanteric region of the femur. Center the C-arm's axis of rotation on the femoral neck of the affected femur.

It is important to ensure that a view of both the distal and proximal ends of the nail can be obtained during the procedure without obstruction by the fracture table.

Fracture reduction

The unaffected leg is abducted as far as possible to make room for the image intensifier (Fig. 17). Traction is applied to the fracture, keeping the leg straight. The legs may be scissored if abduction is not possible.

Maintaining traction, internal rotation of 10-15 degrees may help complete fracture reduction (Fig. 18).

The patient is then prepared and draped as for standard femoral nailing procedures.

When positioning the drapes, bear in mind that the incision will be 2-3 cm proximal to the greater trochanter.

⚠ WARNING

Reduction should be achieved as anatomically as possible. If this is not achievable, reduction should be achieved at least in one plane. Reduction in the other plane may be achieved with the Gamma3 nail during insertion.

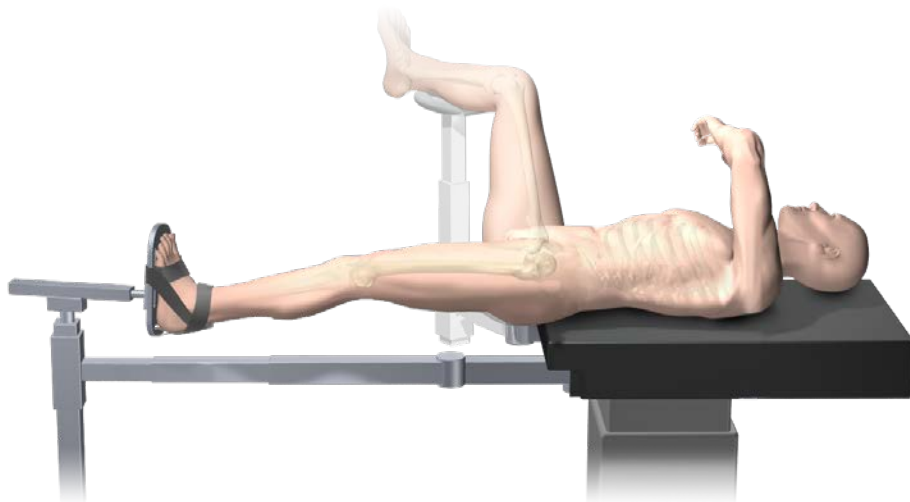

Fig. 16

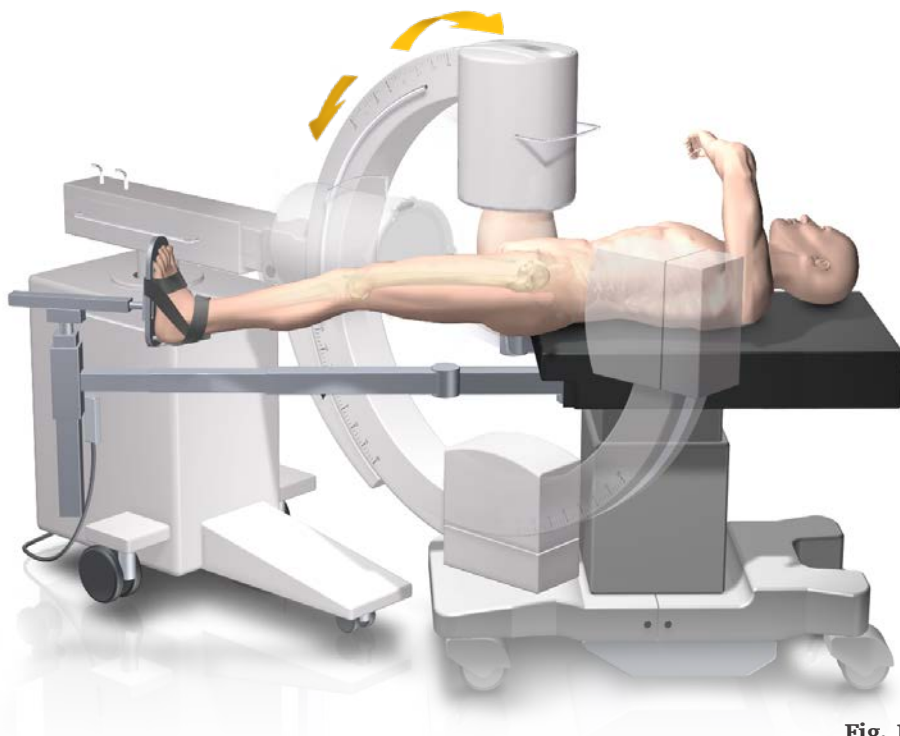

Fig. 17

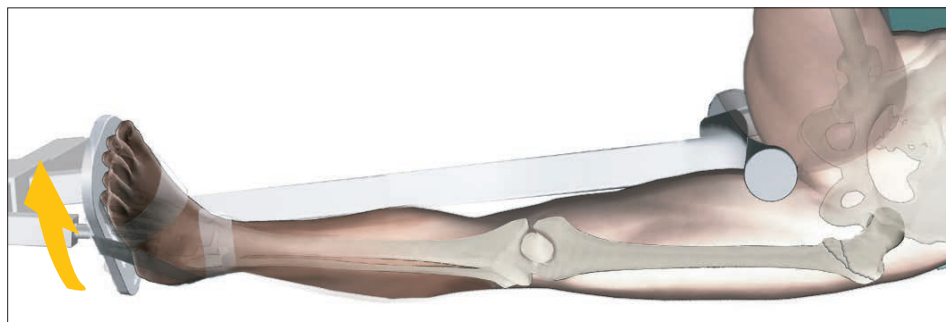

Fig. 18

Operative technique

Special reduction techniques

For specific situations, special techniques have been developed for fracture reduction, and are explained below.

Technique 1: Steinmann pin

In fractures that are particularly difficult to reduce, a transcondylar sterile Steinmann pin may be used. The pin is fixed directly to the orthopaedic table by an adaptable stirrup, and traction is applied until anatomical reduction in the A-P view is obtained (Fig. 19). Closed reduction of the fracture is recommended.

Technique 2: Trunk rotation

Traction is applied to the fracture, keeping the leg straight. To counter misalignment, the trunk is shifted to the opposite side and held in position by a thoracic rest or by a large drape (Fig. 20). This tightens the gluteus medius muscles and relaxes the psoas, externally rotating the proximal fragment into alignment and exposing the greater trochanter for easier introduction of the nail.

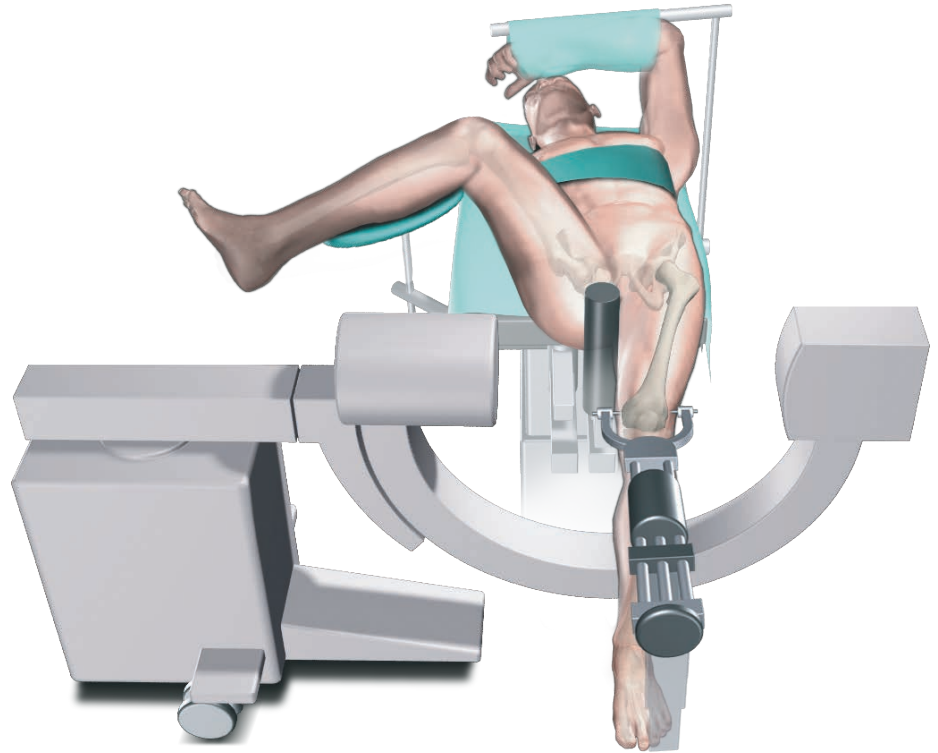

Fig. 19

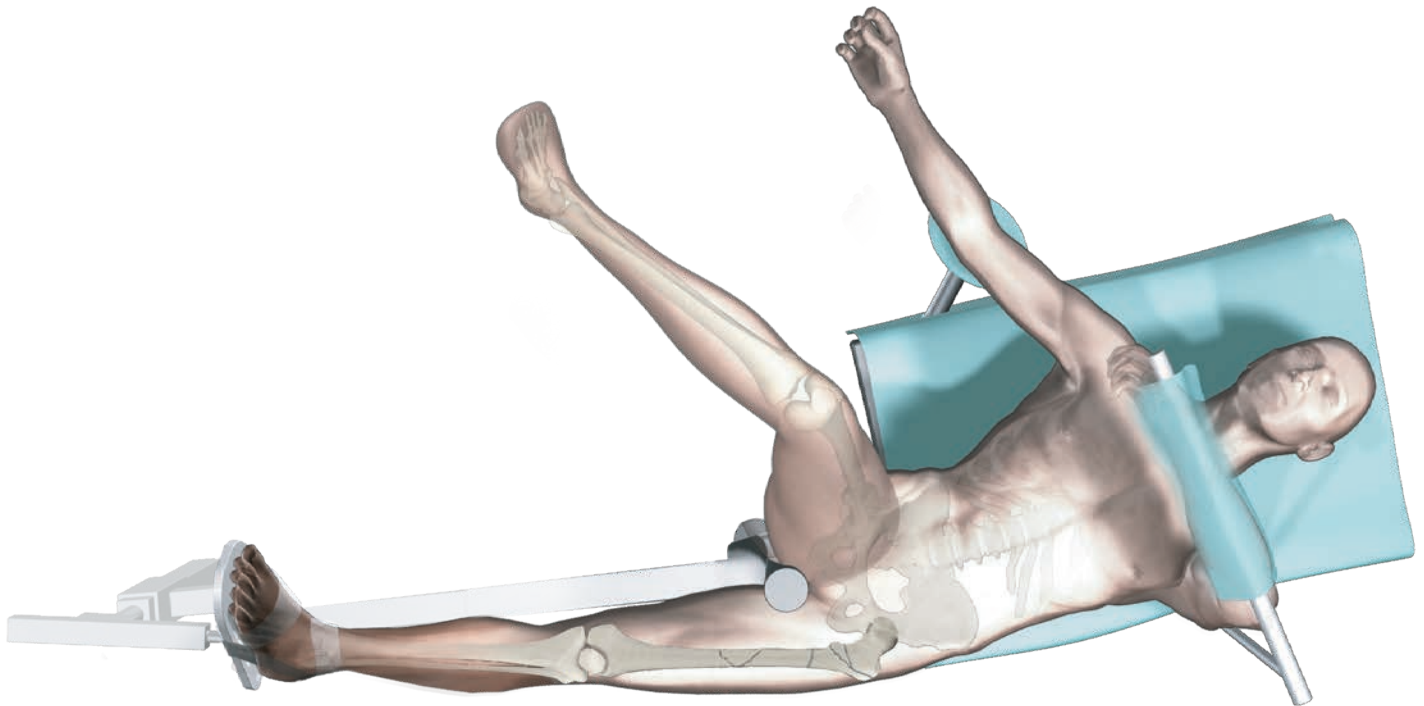

Fig. 20

Operative technique

Technique 3: Universal rod

Subtrochanteric fractures cannot always be reduced during positioning in the lateral view because the proximal fragment is drawn forward by tension from the psoas muscle. This may be reduced during surgery by using the universal rod and the reduction spoon (Fig. 21).

⚠ CAUTION

Care must be taken when introducing the implant as the proximal fragment may rotate during insertion.

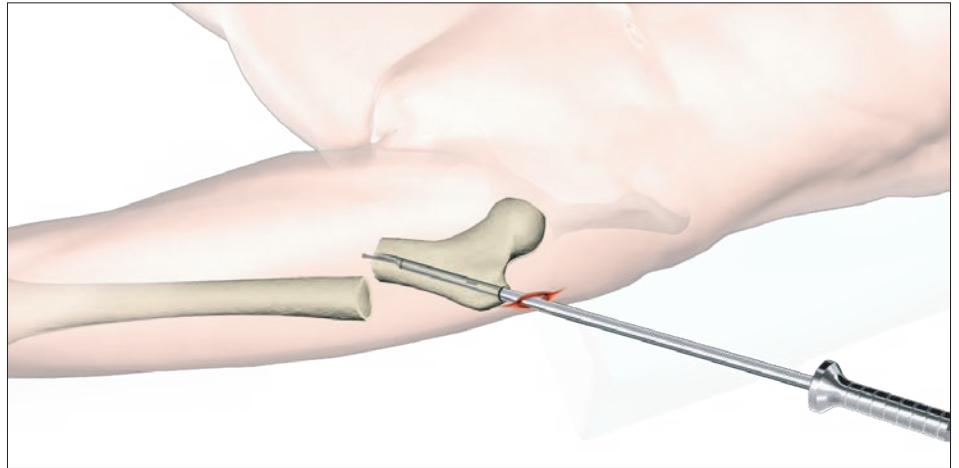

Fig. 21

Technique 4: Reduction spatula

The reduction spatula may aid in fracture reduction. It should be introduced through the incision and slid along the surface of the trochanter until reaching the fracture (Fig. 22a). Lift the handle to manipulate the displaced fragment. You must continue to hold the reduction spatula in place (Fig. 22b) until the lag screw is inserted. Refer to sections 'Lag screw insertion' and 'Lag screw fixation' for more information. Continue to check the A-P and lateral views for proper reduction.

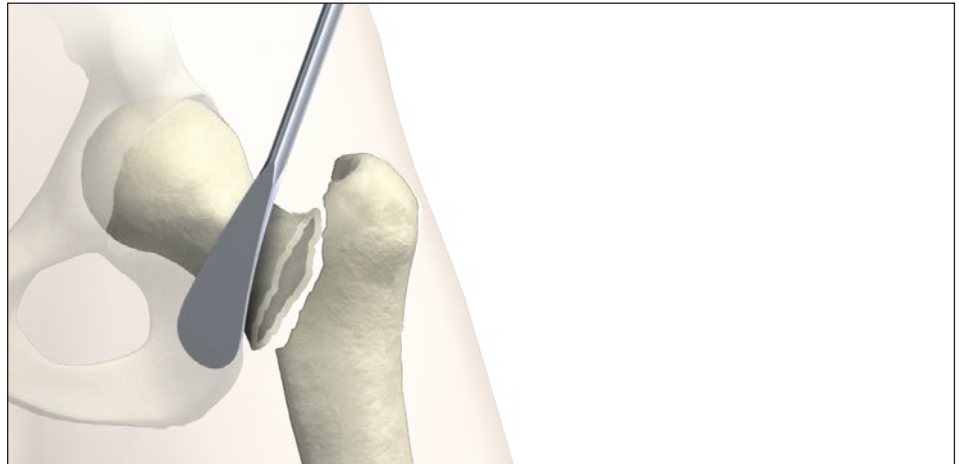

Fig. 22 a

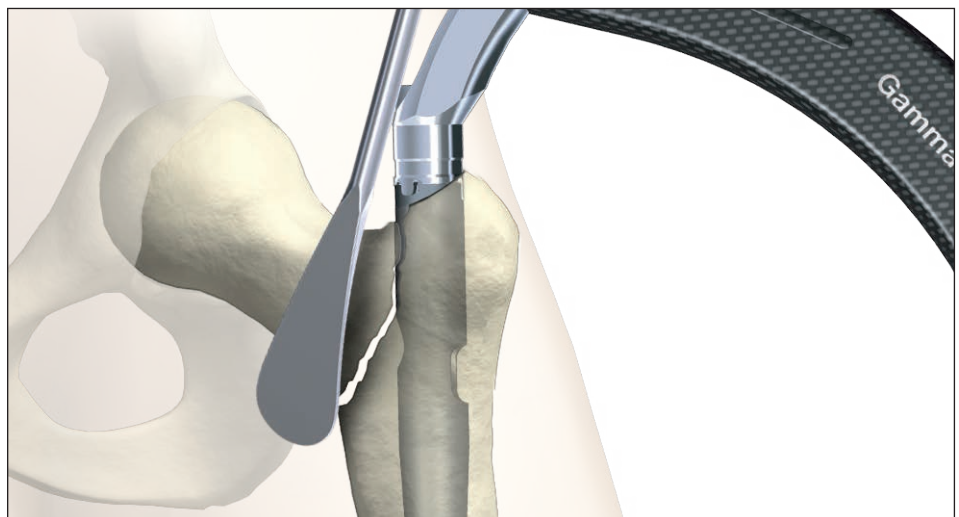

Fig. 22b

Operative technique

Incision

Incisions may be developed in different manners. Two alternatives are described below.

Alternative 1:

The tip of the greater trochanter may be located by palpation (Fig. 23) and a horizontal skin incision is started approximately 2cm cranially from the greater trochanter (depending on the Body Mass Index of the patient) and extended approximately 2 to 3cm towards the direction of the iliac crest (Fig. 24). In larger patients the incision length may need to be longer, depending on body mass index (BMI) of the patient. A small incision is deepened through the fascia lata, splitting the gluteal muscle approximately 1–2cm immediately above the tip of the greater trochanter, thus exposing its tip. A self-retaining retractor, or tissue protection sleeve may be put in place.



Fig. 23

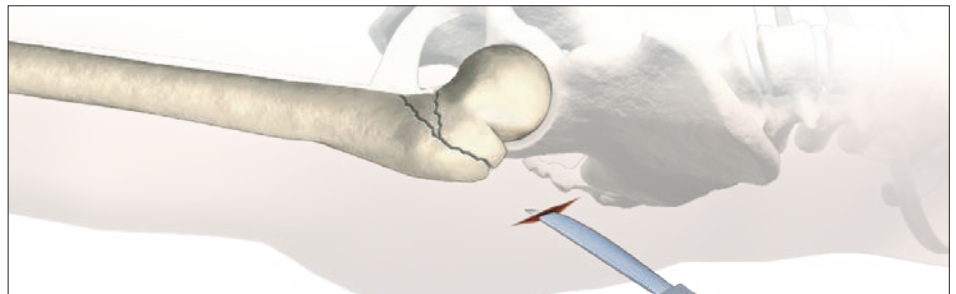

Fig. 24

Alternative 2:

A long and thin metal rod (e. g. screw gauge, long) is placed on the lateral side of the leg. Check with the image intensifier, using M-L view (Fig. 25), that the metal rod is positioned along the bone in the center of the proximal part of the femoral canal passing through the desired entry point (Fig. 26). A line is drawn on the skin (Fig. 27).

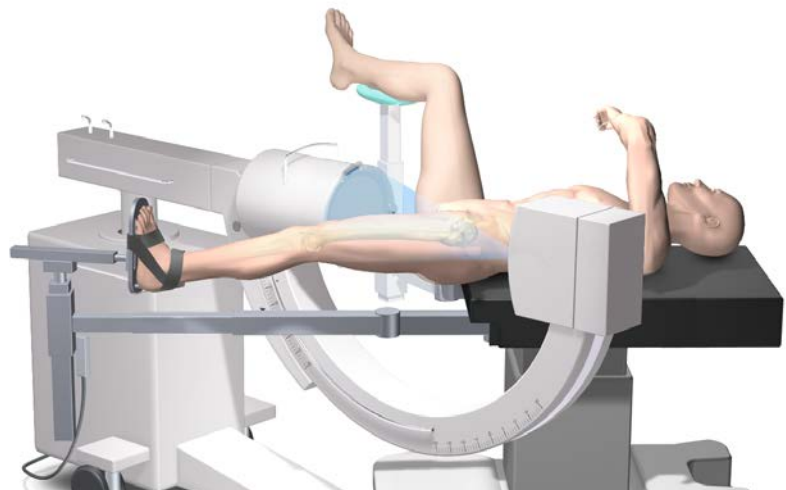

Fig. 25

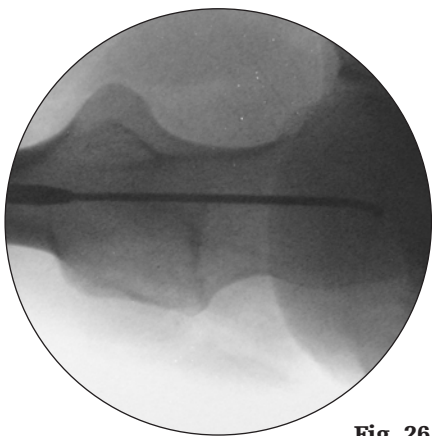

Fig. 26

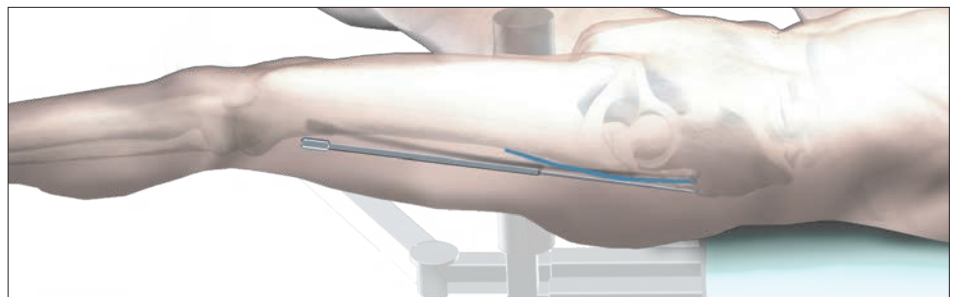

Fig. 27

Operative technique

The C-arm is turned approx. 90° to provide an A-P image of the tip of the trochanter using the metal rod (Fig. 28, Fig. 29).

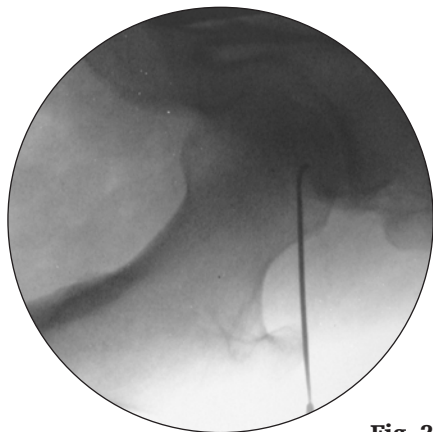

Fig. 28

A vertical line is drawn onto the skin (Fig. 30). The skin incision is made cranially to the indicated intersection, towards the direction of the iliac crest. The distance between the intersection and the starting point for the incision differs, depending on the BMI of the patient. Under normal conditions it is a distance of approximately 2cm (Fig. 31). A small skin incision is made as described in alternative 1 and shown in Fig. 32. Using a finger, the tip of the trochanter should be felt easily (Fig. 33).

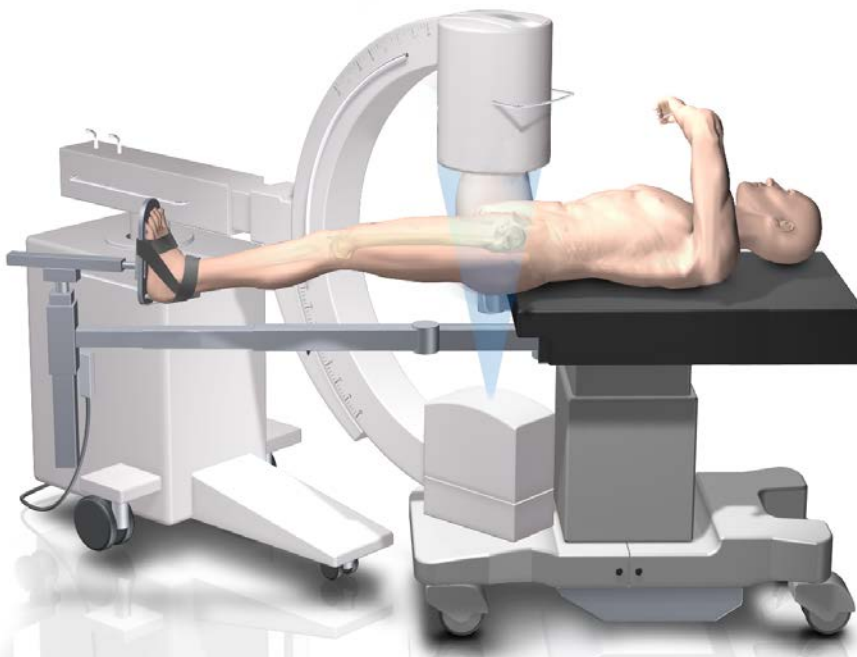

Fig. 29

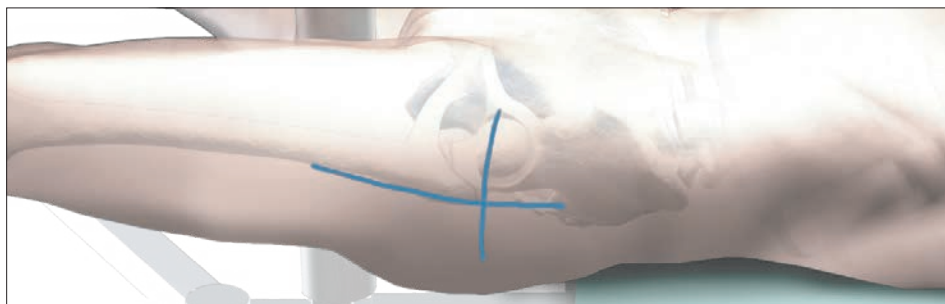

Fig. 30

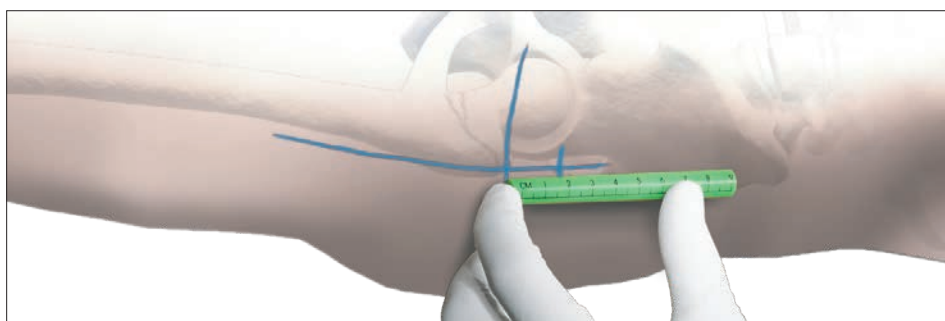

Fig. 31

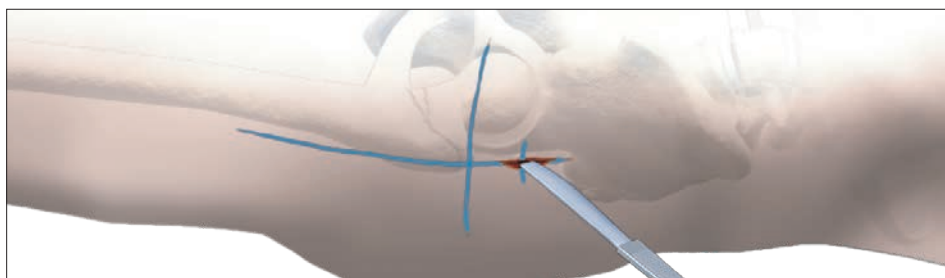

Fig. 32

Operative technique

Entry point

In the A-P view, the entry point is located on the tip of the greater trochanter. In order to define the optimal entry point in the lateral view, nail fit in the proximal diaphysis and lag screw placement in the femoral neck should be considered (Fig. 34). In elderly patients, the optimal entry point is typically located slightly anterior from the center of the greater trochanter. In smaller bones or narrow intramedullary canals (e.g. young patients) a rather posterior position may be chosen.

Opening the cortex

The medullary canal has to be opened under image intensification. The use of the cannulated curved awl (Fig. 35) is recommended if conventional reaming or the one step conical reamer will be used to prepare the canal for the nail. The entry point can also be found by placing a 3.2mm k-wire through the tip of the trochanter, and preparing the medullary canal as described in the next section. The proximal femur can be opened using the rasp awl as described below (Fig. 36).

Alternative 1: Rasp awl

The optional rasp awl combines the feature of the rasp and awl to prepare the proximal femur for the Gamma3 nail. It may provide an option to open the proximal femur cavity without further reaming (Fig. 36).

⚠ CAUTION

During opening the entry point with the awl or rasp awl, cortical bone may block the tip. A plug can be inserted through either awl to avoid penetration of bone debris into the cannulation of the awl shaft.

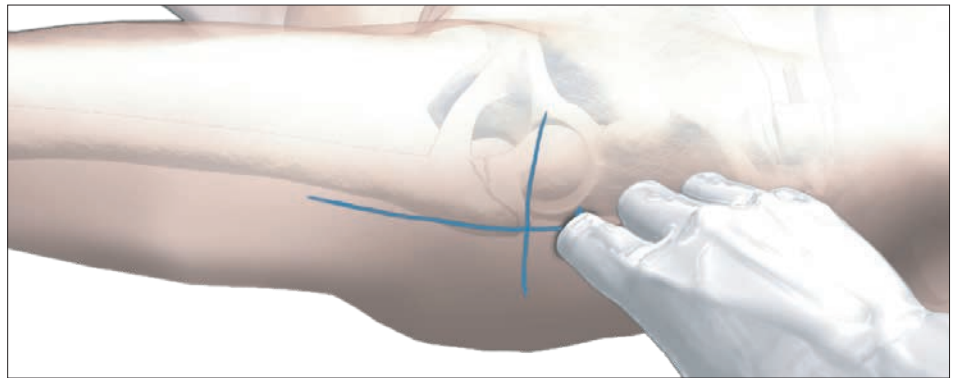

Fig. 33

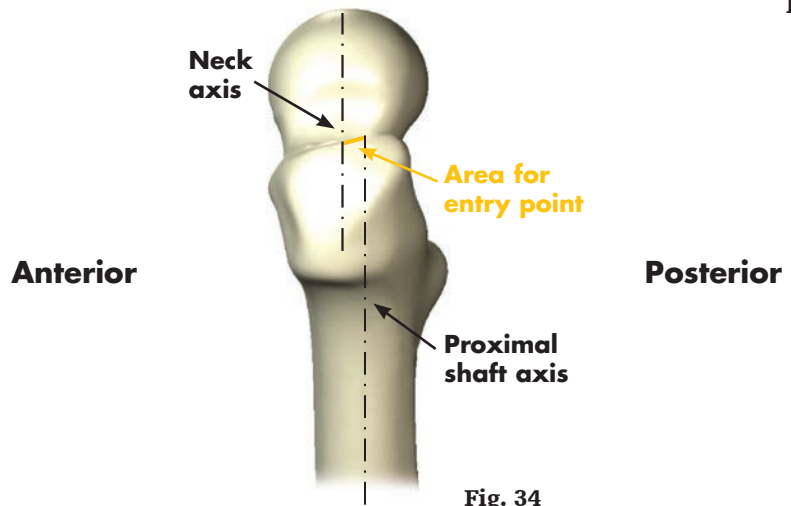

Fig. 34

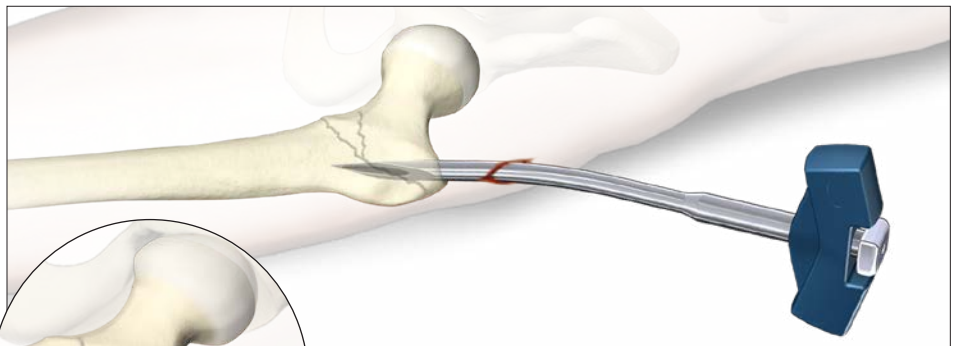

Fig. 35

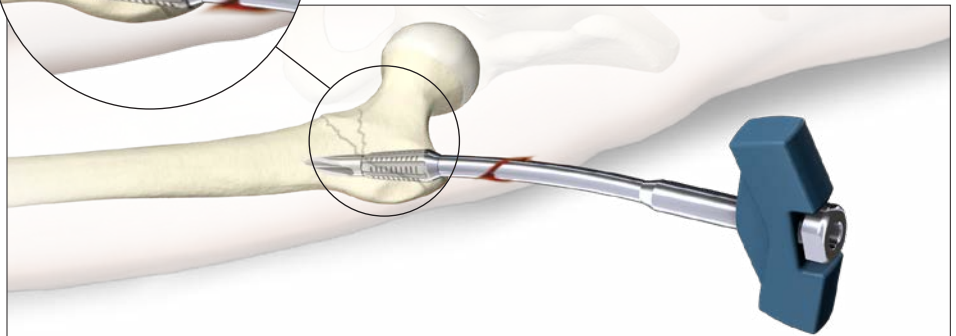

Fig. 36

Operative technique

Entry point optimization

The k-wire position may be corrected using a second k-wire in combination with the multi-hole trocar (Fig. 37). Four eccentric holes offer corrections with different off-sets, ranging from 4.0 to 5.5mm from the center hole. Refer to markings on the multi-hole trocar for dimensions (Fig. 38).

If opening with the curved awl is performed, the assembly of conical reamer trocar or multi-hole trocar and conical reamer sleeve is inserted over the 3mm guide wire (use center hole if multi-hole trocar is used) to the tip of the trochanter.

⚠ WARNING

K-wires are not intended for re-use. They are single use only. K-wires may be damaged or bent during surgical procedures. If a k-wire is reused, it may get lodged in the cannulated devices and could be advanced into the pelvis, and may damage large blood vessels or cause other serious injuries.

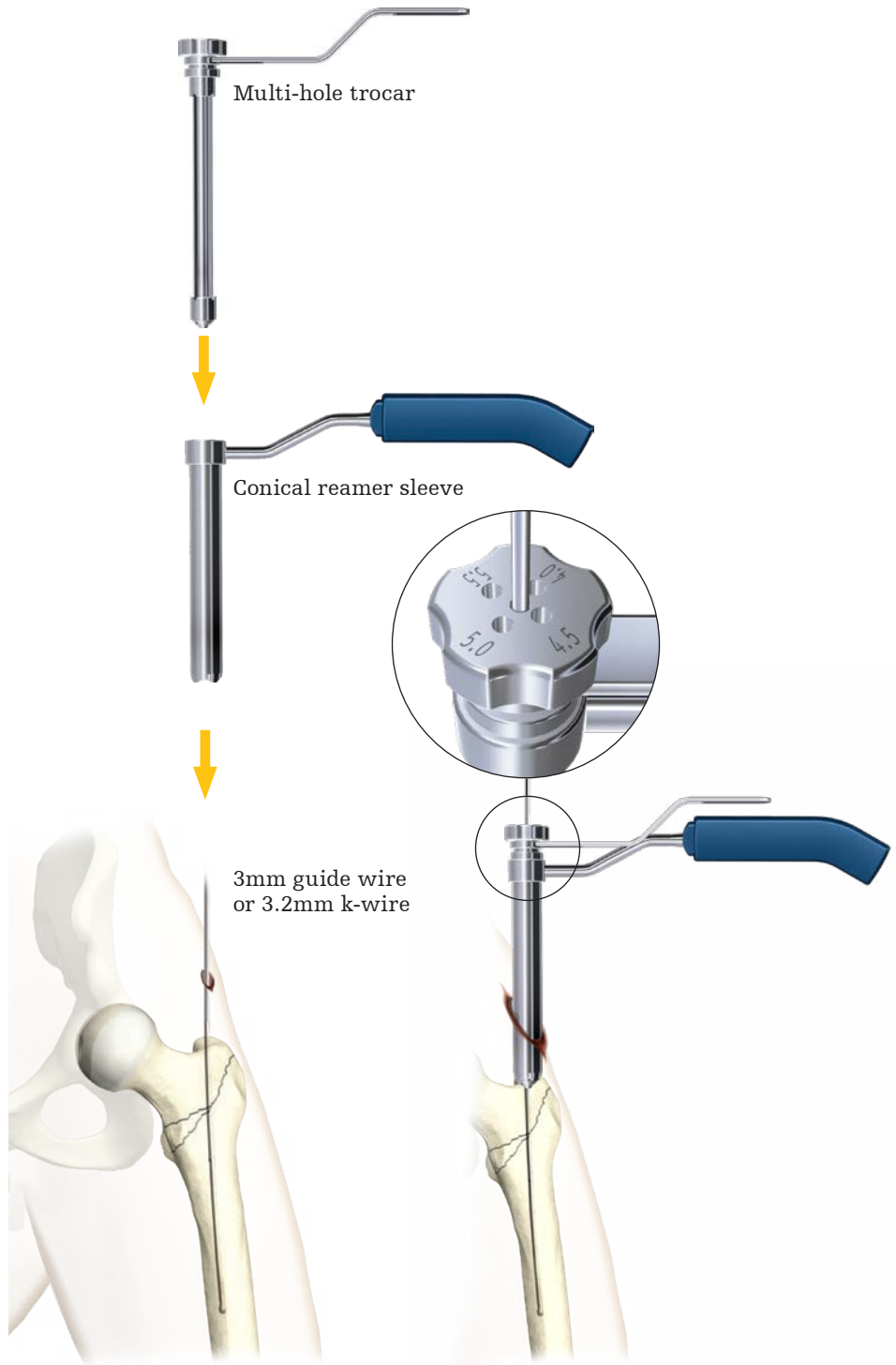

Fig. 37

Fig. 38

Operative technique

Preparation of the medullary canal

The Gamma3 system includes four options to prepare the medullary canal. These options are described below. When the Gamma3 Trochanteric Nails are used, reaming of the subtrochanteric and diaphyseal region of the femoral cavity may not be required, particularly in elderly patients with wide medullary canals.

Alternative 1: Reaming the medullary canal

A 3mm ball-tipped guide wire is recommended as a reamer guide. Pass the guide wire through the cannulated curved awl, or other opening device, into the shaft of the femur as shown, using the guide wire handle (Fig. 39). The ball-tipped guide wire must be used to prevent over insertion of the reamer (Fig. 40).

Rotating the guide wire during insertion makes it easier to achieve the desired position in the middle of the medullary canal. Prior to reaming, the distal position of the ball-tipped guide wire should be confirmed with the image intensifier. Care must be taken not to penetrate through the knee joint.

The canal should be reamed at least 2mm larger than the distal diameter of the nail. Flexible reamers are used to ream the shaft of the femur in stages starting from 9mm diameter and increasing in 0.5mm increments. In some narrow medullary canals, over-reaming greater than the suggested amount above may be required.

When reaming is performed, the entire femoral canal should be over-reamed down through the isthmus, in order to avoid a stress riser in the bone.

In order to accommodate the proximal part of the Gamma3 nail, the subtrochanteric region must be opened up to 15.5mm (Fig. 41). This can be done either by reaming with the Stryker Bixcut Reaming System or, alternatively, with the one step conical reamer.

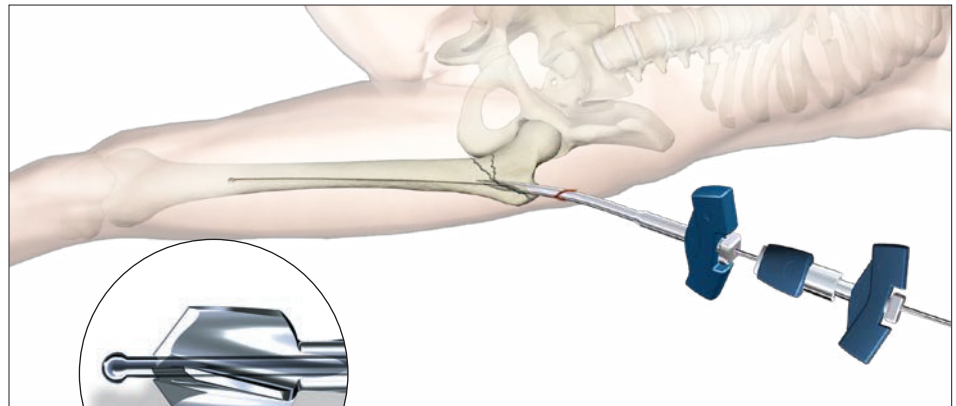

Fig. 40

Fig. 39

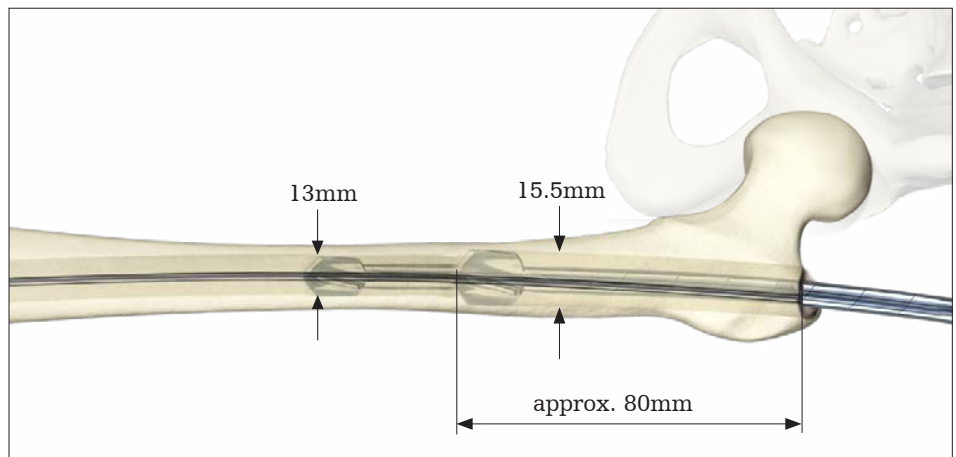

Fig. 41

⚠ CAUTION

For soft tissue protection, the conical reamer sleeve should be used during reaming.

⚠ CAUTION

Care must be taken with flexible reamers to ensure that the guide wire is not displaced laterally during reaming. This could lead to resection of more bone on the lateral side, which in turn would lead to an offset position for the nail and a risk of shaft fracture.

Operative technique

Alternative 2: One step conical reamer

The one step conical reamer may be used to prepare the proximal canal of the trochanter using only one drilling step (Fig. 42).

The one step conical reamer is connected to the t-handle and slid over a guide wire or k-wire to the tip of the trochanter. With gentle turning and pushing movements, the conical reamer will prepare the canal for the proximal part of the Gamma3 nail. The one step conical reamer stops when the correct depth is reached. If a 3.2mm k-wire was used, it should now be replaced with a guide wire.

⚠ CAUTION

The one step conical reamer is a front and side cutting instrument and should be used with great care to ensure that the sharp edges of the reamer do not damage intact bone inadvertently.

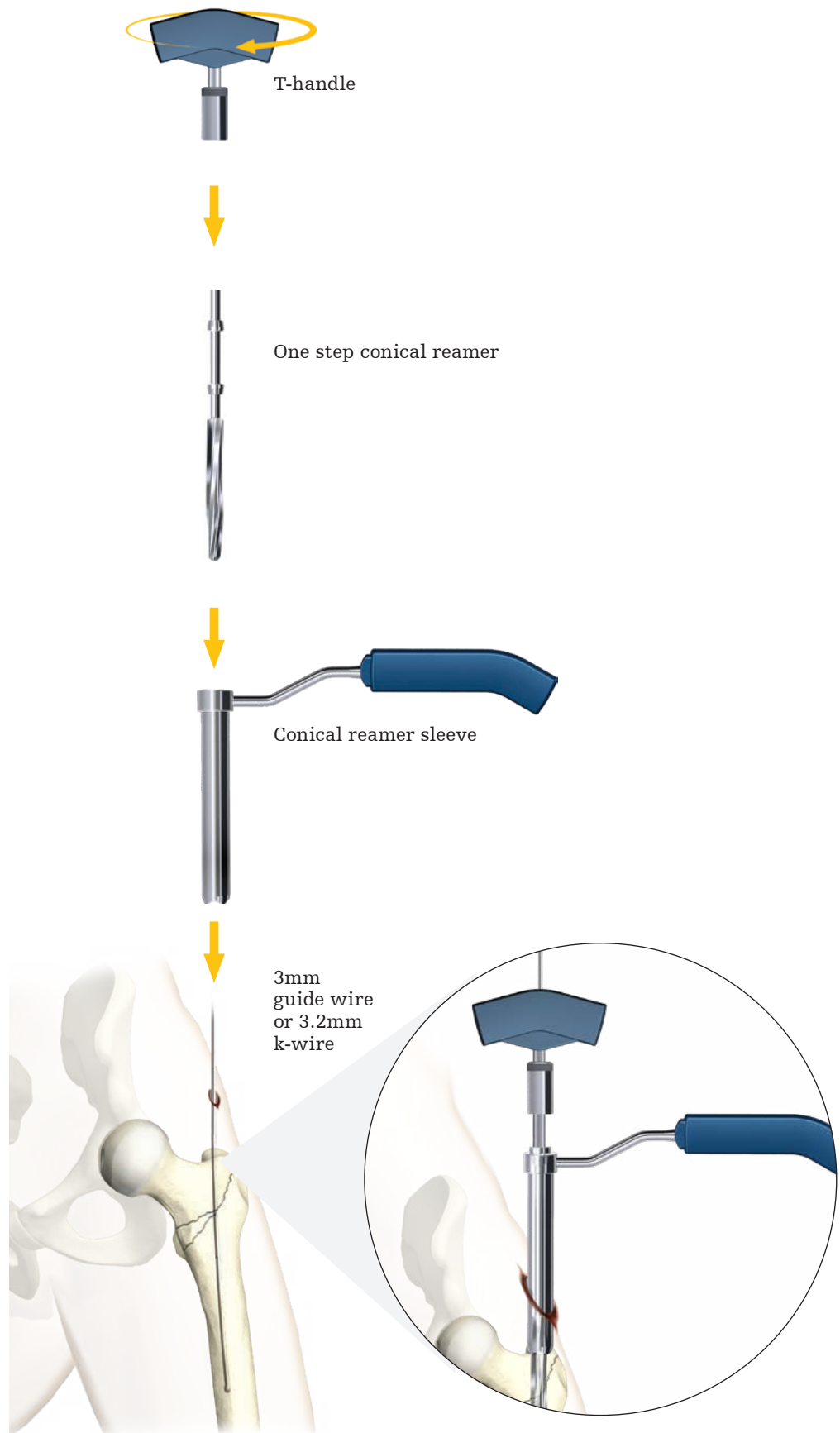

Fig. 42

Operative technique

Alternative 3: Cannulated cutter

The cannulated cutter may be used to prepare the proximal canal of the trochanter without reaming. This device is designed to allow for easy collection of bone graft material which might be helpful in difficult healing conditions.

A 4.0mm guide pin is placed through the tip of the trochanter. The cannulated cutter is slid over the guide pin to the tip of the trochanter. With gentle turning and pushing movements, the canal for the proximal part of the Gamma3 nail is prepared. Refer to Fig. 43 and Fig. 44.

CAUTION

When the cannulated cutter is used, do not open the cortex with the awl, because the awl usually creates larger holes than 4.0mm. The 4.0mm guide pin needs bony stability to provide optimal cutting performance of the cannulated cutter.

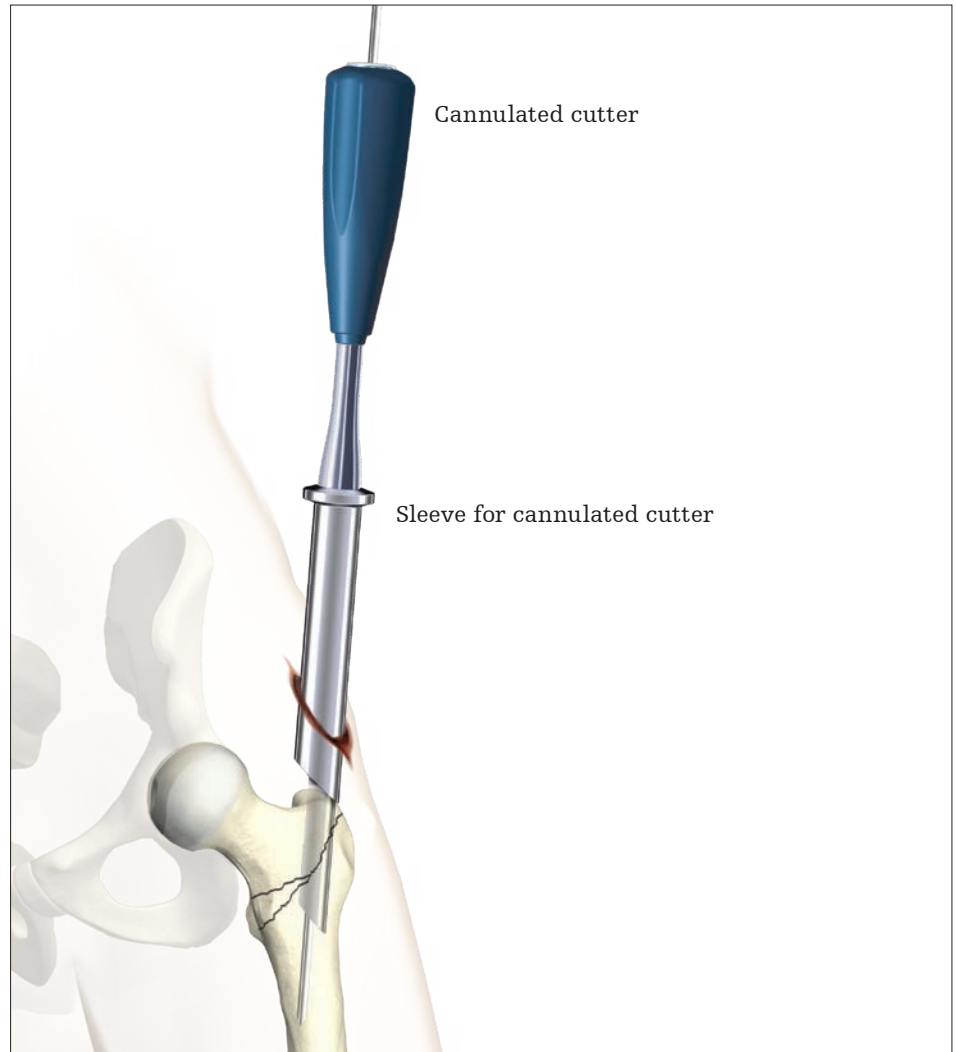

Fig. 43

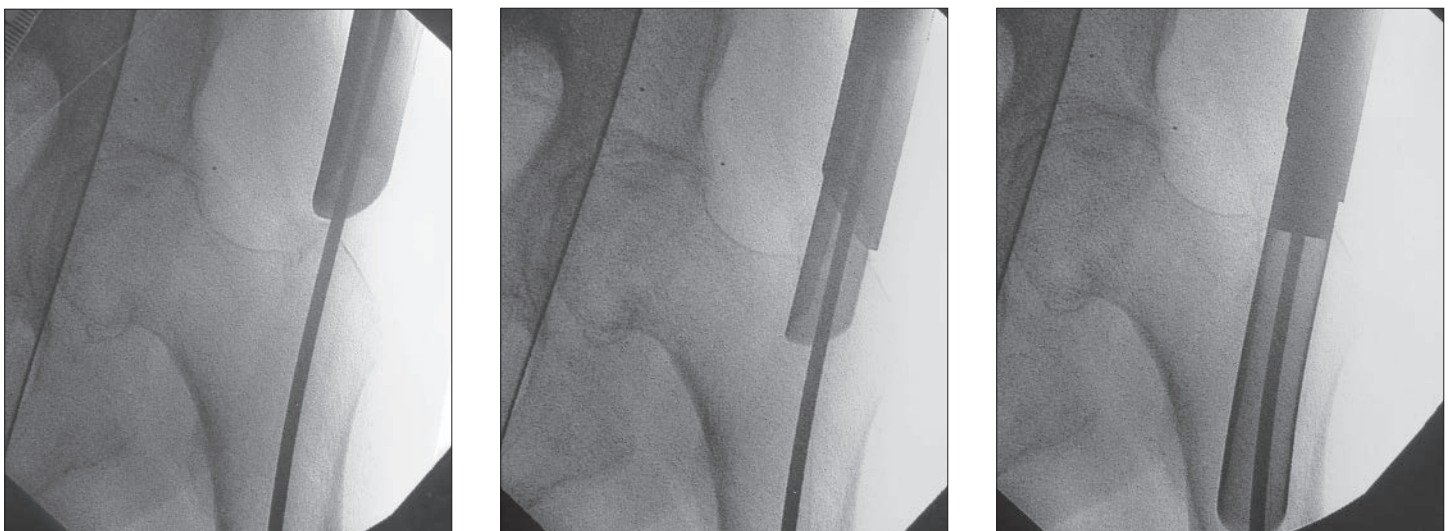

Fig. 44

Operative technique

Alternative 4: Crown drill

The crown drill may be used to prepare the proximal canal of the trochanter. It is designed to prevent fragment distraction at the entry portal and to allow for easy collection of bone graft material which might be helpful in difficult healing conditions.

Once the entry point is determined, insert the k-wire with washer through a small incision using the guide wire handle until the washer reaches the surface of the greater trochanter (Fig. 45, Fig. 46).

⚠ CAUTION

Do not open the cortex with the awl when using the crown drill, as the awl creates a hole larger than 3.2mm. The 3.2mm k-wire needs bony stability to provide optimal crown drill cutting performance.

Connect the crown drill to the t-handle and slide it over the k-wire to the tip of the greater trochanter. With gentle turning and pushing movements, the crown drill will prepare the canal for the proximal part of the Gamma3 nail. The crown drill stops when the correct depth is reached.

⚠ CAUTION

If using a power tool to drive the crown drill, particular attention must be paid to the position of the k-wire. The crown drill is a front and side cutting instrument and should be used with great care to ensure that the sharp edges of the reamer do not inadvertently ream intact bone.

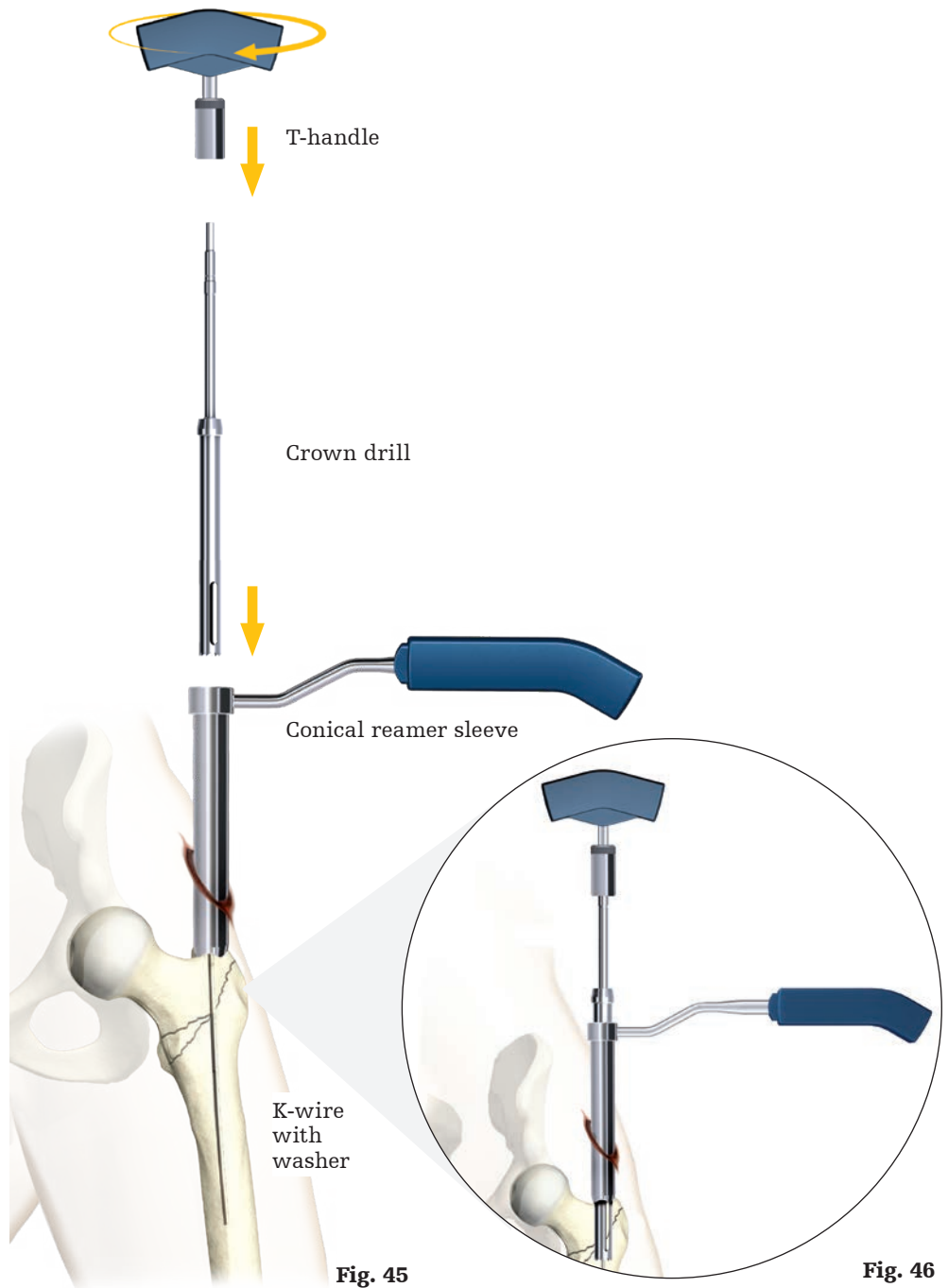

Long nail length

Place the guide wire ruler over the guide wire onto the bone. The end of the guide wire indicates the length between the tip of the guide wire and the tip of the guide wire ruler (placed on bone) in order to select the appropriate nail length. Make sure that the markings correspond to the correct guide wire length. Refer to Fig. 47.



End of guide wire ruler is the measurement reference

Fig. 47

Operative technique

Assembly of proximal target device and implant

1. Target device and speedlock sleeve assembly

The proximal target device and speedlock sleeve assembly (Fig. 48) is designed to allow for guided lag screw locking of all nails and distal locking of trochanteric nails. For guided distal locking of long nails, refer to the 'Distal targeting system' section.

Depending on the trochanteric nail selected (170mm, 180mm or 200mm), the corresponding speedlock sleeve shall be used. For long nails, any speedlock sleeve can be used for lag screw placement.

Push the speedlock sleeve over the target device along the line until it stops (arrow line to arrow line).

Rotate the speedlock sleeve around to the required nail angle position for the lag screw, e.g. 125° (dot to dot) or distal locking positions, either "dynamic" or "static". Now the speedlock sleeve must be fixed in this position by pushing it against the target device. You will feel and hear as the sleeve snaps into position.

By turning the speedlock sleeve knob clockwise into the "lock" position, the speedlock sleeve can be locked to the target device. To unlock the speedlock sleeve for insertion of the lag screw guide sleeve or tissue protection sleeve, the knob must be turned counter-clockwise.

As an alternative target device, the Gamma3 Plus may be used. The assembly is the same as described above.



Fig. 48

Operative technique

2. Assembly of the target device and the Gamma3 nail

The selected Gamma3 nail is now assembled to the target device (Fig. 49).

Ensure that the target device pins fit into the corresponding notches of the proximal part of the nail. Fixate the assembly with the nail holding screw by using the ball tip screwdriver.

CAUTION

Fully tighten the nail holding screw with the ball tip screwdriver, so that it does not loosen during nail insertion.

Prior to nail insertion, check the following functions of the target device (Fig. 50):

1. Lag screw guide sleeve matches the selected nail angle.
2. Distal locking position of the tissue protection sleeve matches the required "static" or "dynamic" locking position.



Fig. 49

Operative technique

⚠ CAUTION

Prior to nail insertion, the implant and instrument assembly must be checked. Ensure that the sleeve angle matches the corresponding nail angle chosen, e. g. a 125° position in speedlock sleeve for a 125° nail, and the distal sleeve matches either for “dynamic” or “static” locking as required.

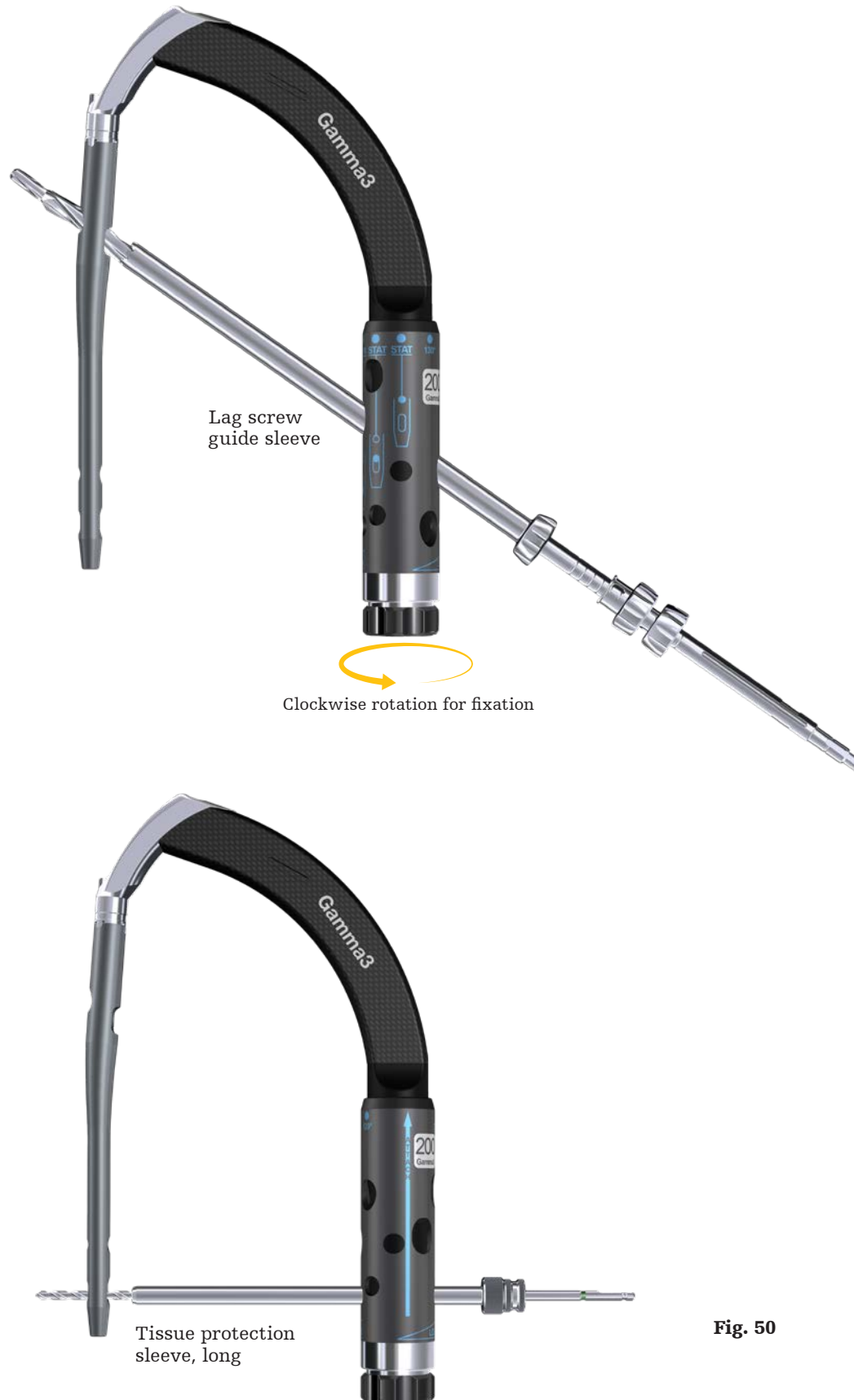

Fig. 50

Operative technique

Nail insertion

The nail is advanced through the entry point passing the fracture site to the appropriate level (Fig. 51).

If dense bone is encountered, first re-evaluate that sufficient reaming has been achieved, then, if necessary, the strike plate (or cannulated impactor if Gamma3 Plus is used; Fig. 53) can be attached to the target device and the slotted hammer may be used with caution to further insert the nail (Fig. 52).

⚠ CAUTION

The target device should never be struck as it may break or become deformed.

⚠ DANGER

The nail must progress smoothly, without excessive force. If too much resistance is encountered, removal of the nail and additional reaming is recommended.

If the nail is positioned too proximal, correction of the nail should be carried out by hand (Fig. 51) or by using the strike plate (or cannulated impactor when Gamma3 Plus is used) threaded into the target device (Fig. 52). The nail holding screw should be re-tightened following any use of the impactor. If a higher position is required, the universal rod may then be attached to the strike plate (only for Gamma3 Target Device, Threaded Post) to carefully and smoothly extract the assembly (Fig. 52). The new position is checked again with the image intensifier as described above.

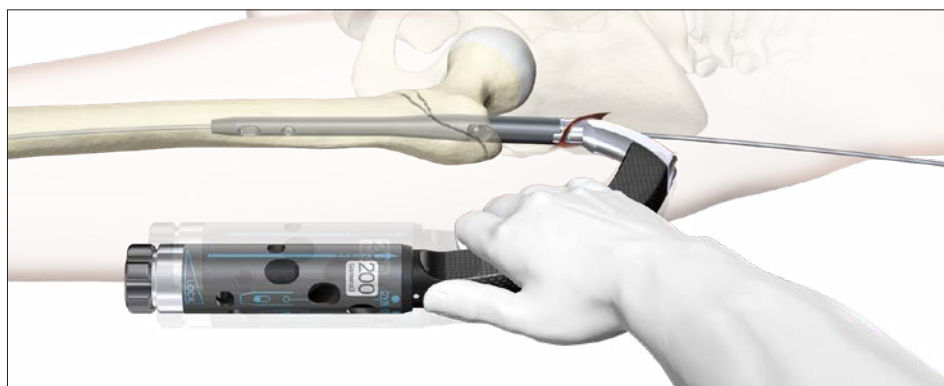

Fig. 51

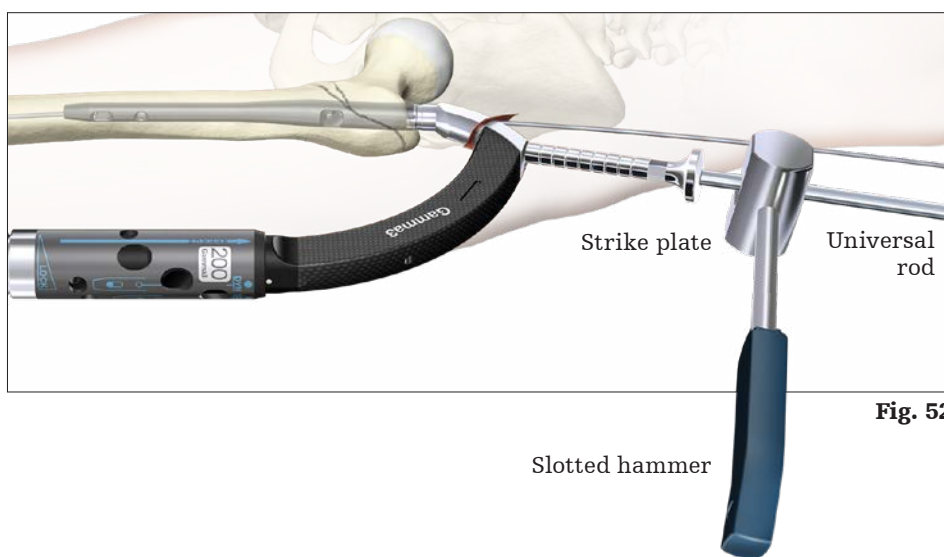

Fig. 52



Fig. 53

Operative technique

Implant positioning

Proper nail insertion depth and rotation ensures an optimal placement of the lag screw in the femoral head. The objective is to position the lag screw either in the center or slightly inferior in the femoral head in the A-P view and centrally in the lateral view, to provide the best load transfer to the lag screw. Stryker's ADAPT for Gamma3 system may be used to aid in implant positioning. Contact your Stryker sales representative or refer to the corresponding labeling for more information.

Place the lag screw guide sleeve up to the level of the skin and acquire an A-P X-ray image. The sleeve may be used to determine the optimal nail insertion depth (Fig. 54).

Once satisfied with the nail depth, rotate the C-arm to the lateral position and acquire an X-ray image. A true lateral image can be achieved by aligning the femoral neck axis parallel to the proximal diaphysis. This can be done by either tilting the fracture table or rotating the C-arm into the correct position. Rotate the target device until the axis of the target device and nail is collinear with the femoral neck axis (Fig. 55).

In the lateral X-ray image, the closed tube clip and u-wire may be used to aid in rotational alignment and projection of the k-wire and lag screw position (Fig. 56). The Gamma 3 Closed Tube and ADAPT Clips are not compatible with the Gamma3 Plus Target Device, but the u-wire may still be used by inserting it through the openings in the plus target device (Fig. 57).

The closed tube clip is assembled onto the target device by squeezing the flanges together and placing it onto the target device. Push the clip medially to lock it on the target device. For more details, refer to section 'Alternative: Set screw insertion with Gamma3 Closed Tube & ADAPT Clip. The u-wire is inserted through the openings in the clip. To properly project the placement of the k-wire and lag screw, the wires must overlap so only one wire is seen (Fig. 56).

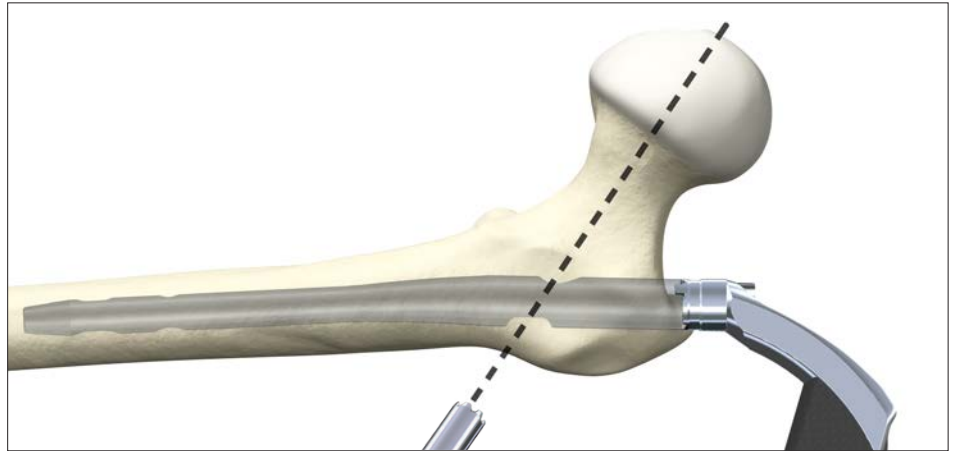

Fig. 54



Fig. 55

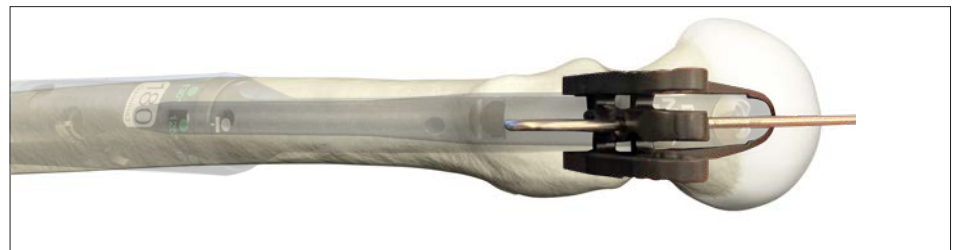

Fig. 56

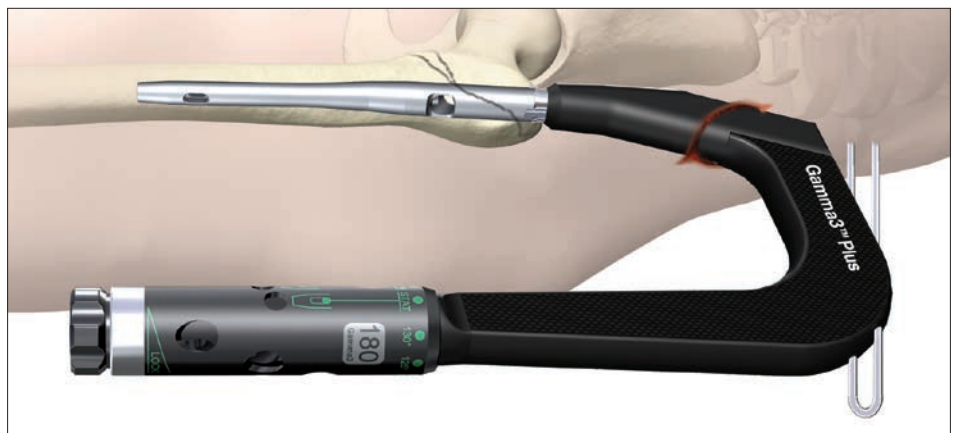

Fig. 57

Operative technique

Implant positioning with one shot device

Alternatively, the one shot device may be used to predict the lag screw position in both, A-P and lateral views by symmetrical alignment of the metal markers of the one shot device. To assemble the one shot device:

1. Push the lag screw guide sleeve through the target device up to the level of the skin.
2. Lock the one shot device on the shaft of the lag screw guide sleeve by the clothes pin mechanism before the skin incision is performed (Fig. 58).
3. Turn the one shot device under X-ray (A-P view) until the dotted center line is projected in the center of the lag screw opening and between the solid lines. Adjust the nail insertion depth until the one shot device markers show up center in the femoral neck or slightly inferior (Fig. 59).
4. Turn the C-arm and one shot device into a lateral position (Fig. 61).
5. Independent from the C-arm and one shot device alignment, the first step should be to turn the nail and target device onto the plane of anteversion. Turn the target device until the solid lines are parallel to the femoral neck axis.
6. The one shot device is then turned until the dotted center line is aligned symmetrically between the solid lines. An optimal lag screw position is achieved when the dotted center line shows up in the center of the femoral head (Fig. 60).

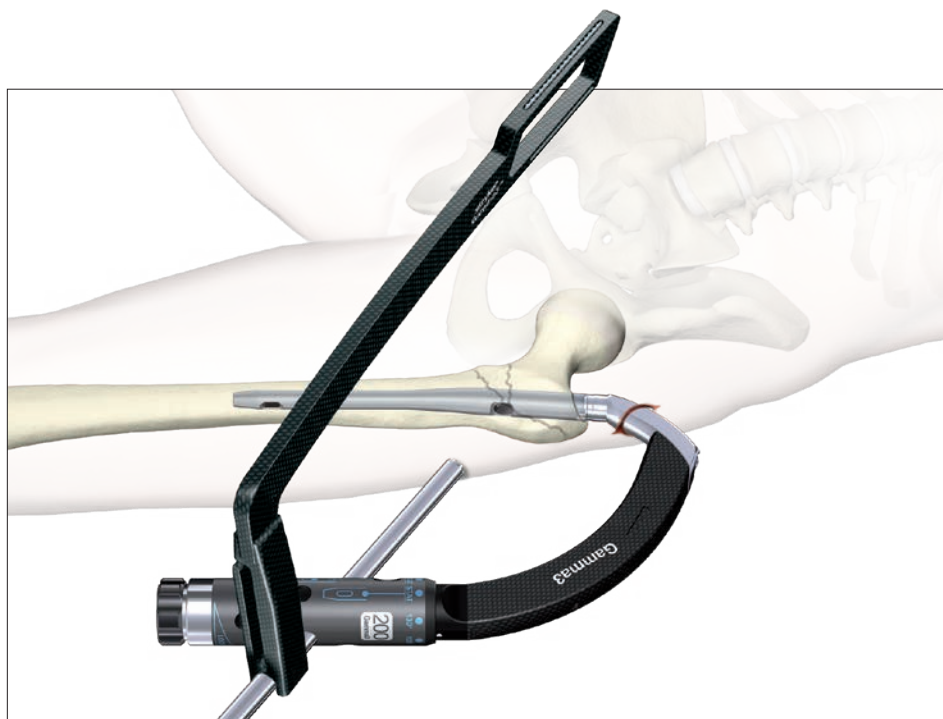

Positioning of nail depth

Fig. 58

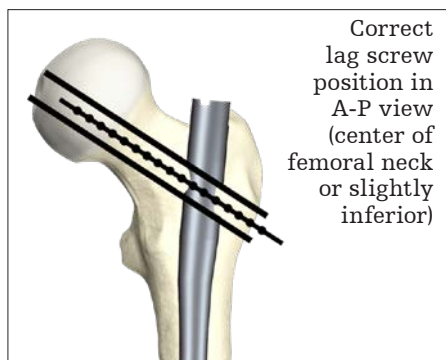

Correct lag screw position in A-P view (center of femoral neck or slightly inferior)

A-P view

Fig. 59

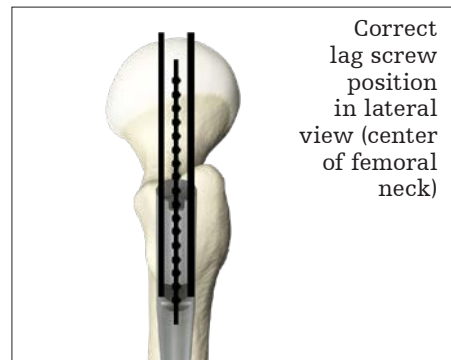

Correct lag screw position in lateral view (center of femoral neck)

Lateral view

Fig. 60

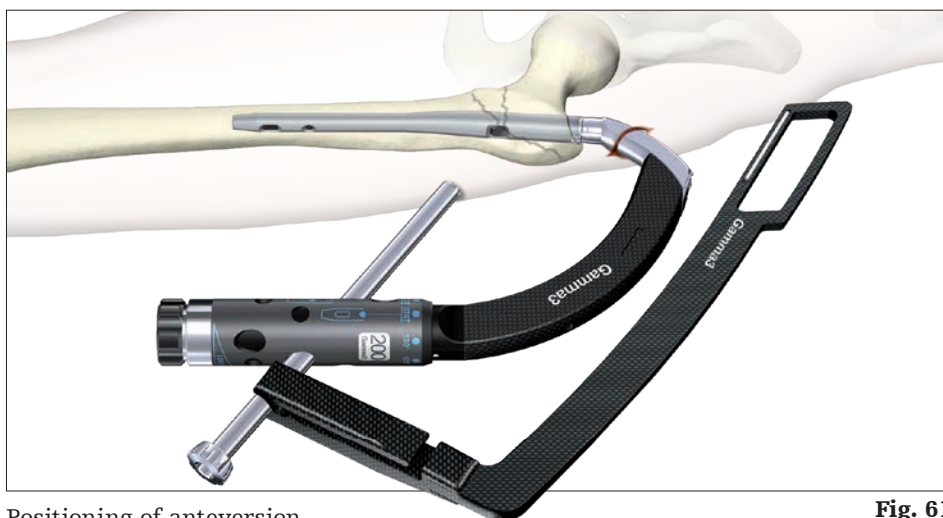

Positioning of anteversion

Fig. 61

Operative technique

⚠ CAUTION
Before proceeding, check that the guide wire for the flexible reamer and nail insertion used earlier has been removed.

K-wire placement

The target device may be held by an assistant to prevent its weight from externally rotating the nail until the next stage is completed.

As an optional solution to facilitate the smooth insertion of the sleeve assembly, the paddle tip trocar can be used prior to the use of the drill guide sleeve. Assemble the lag screw guide sleeve with the paddle tip trocar and pass them through the target device to the level of the skin. Make the skin incision down to the bone. Pass the trocar and guide sleeve through the incision. When the tip of the paddle trocar catches the fascia lata, twist it manually. There is a mark at the head of the paddle tip trocar that provides the direction of the trocar tip. The trocar and guide sleeve should be advanced until the sleeve rests on the lateral cortex (Fig. 62), and the trocar extends past the sleeve (Fig. 63).

Prior to k-wire placement, pre-drilling of the lateral cortex with the 4.2mm drill is recommended to prevent deflection during k-wire insertion. Insert the green coded 4.2mm drill guide sleeve into the lag screw guide sleeve to the level of the skin (Fig. 64). The guide sleeve assembly is now advanced through the incision. If the guide catches the fascia lata, twisting it will usually allow it to pass through to the bone.

For an accurate lag screw length measurement, the outer guide sleeve must be in good contact with the lateral cortex of the femur (Fig. 65). The knob of the speedlock sleeve must be turned clockwise to lock the guide sleeve in place and further stabilize the targeting assembly (Fig. 66).

⚠ CAUTION
Before proceeding ensure that the nail holding screw is still fully tightened.

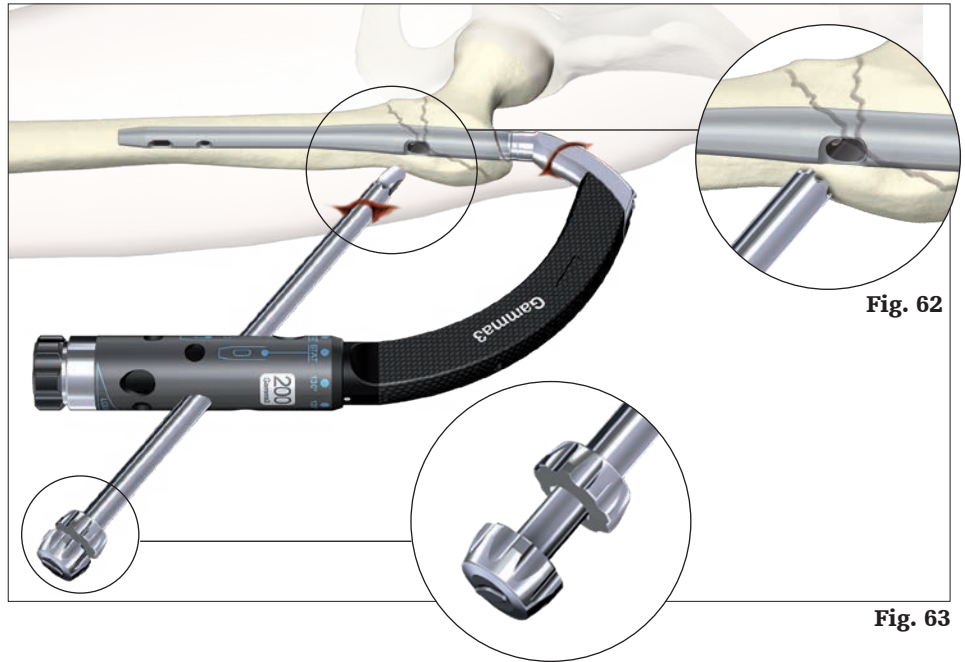

Fig. 62

Fig. 63

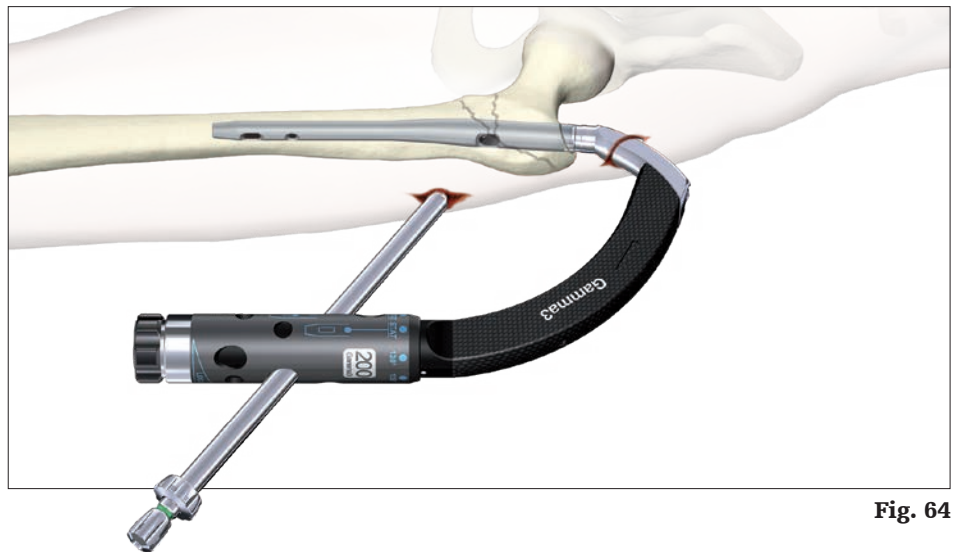

Fig. 64

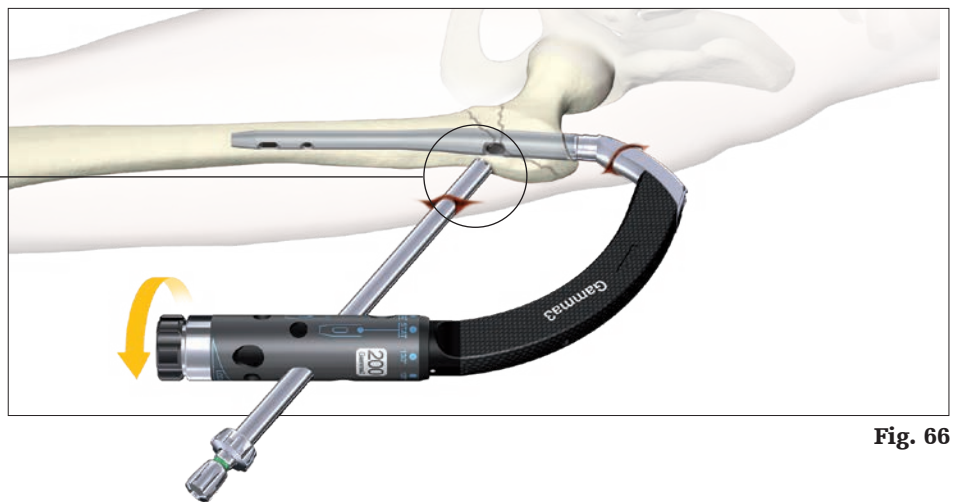

Fig. 66

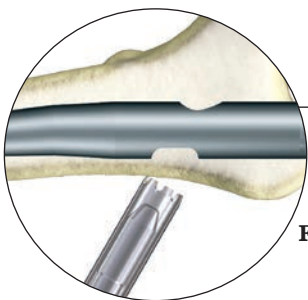

Fig. 65

Operative technique

With the tip of the guide sleeve assembly placed on the lateral cortex, the green coded 4.2mm x 360mm drill should be used to pre-drill the path for the k-wire (Fig. 67). This may prevent skiving of the k-wire during insertion.

The green coded 4.2mm drill guide sleeve is then replaced by the k-wire sleeve. Both sleeves look similar, but have different inner hole diameters. The k-wire sleeve has no colored ring (Fig. 68).

The single use k-wire inserted through the k-wire sleeve should be advanced up to the subchondral bone (Fig. 68, Fig. 69), using the guide wire handle or using a power tool. Ensure that the k-wire is placed either central or in the lower half of the femoral head in the A-P view and on the midline in the lateral view (Fig. 69).

⚠ WARNING

- **Pre-drilling offers a possibility to open the lateral cortex for the k-wire entry. Pre-drilling helps to prevent a possible slipping of the k-wire on the cortex and may avoid deflection within the femoral head. This helps to perform the lag screw reaming without nail contact.**
- **Check the proper k-wire position with the image intensifier in both the anterior-posterior and mediolateral views as shown in Fig. 69 to ensure that k-wire deflection did not occur.**
- **In the event the nail is damaged during lag screw reaming, the fatigue strength of the implant may be reduced which may cause nail to fracture.**
- **K-wires are not intended for re-use. They are single use only. K-wires may be damaged or bent during surgical procedures. If a k-wire is reused, it may get lodged in the cannulated devices and could be advanced into the pelvis, and may damage large blood vessels or cause other serious injuries.**

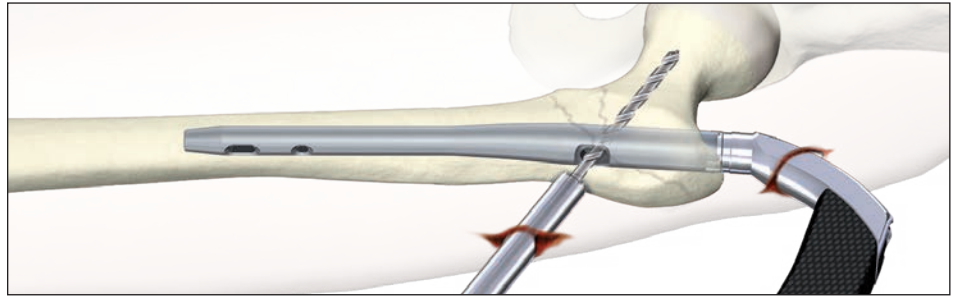

Opening of the lateral cortex

Fig. 67

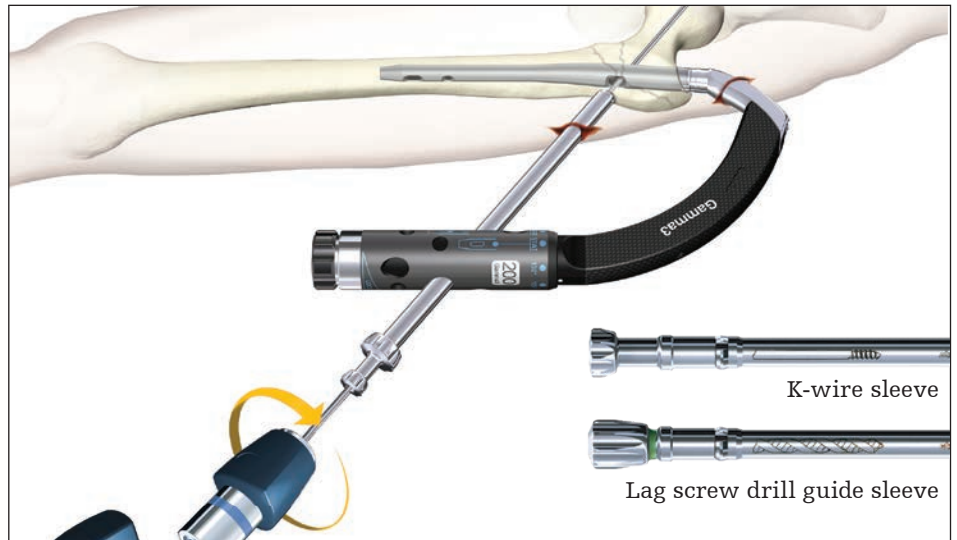

K-wire placement

Fig. 68

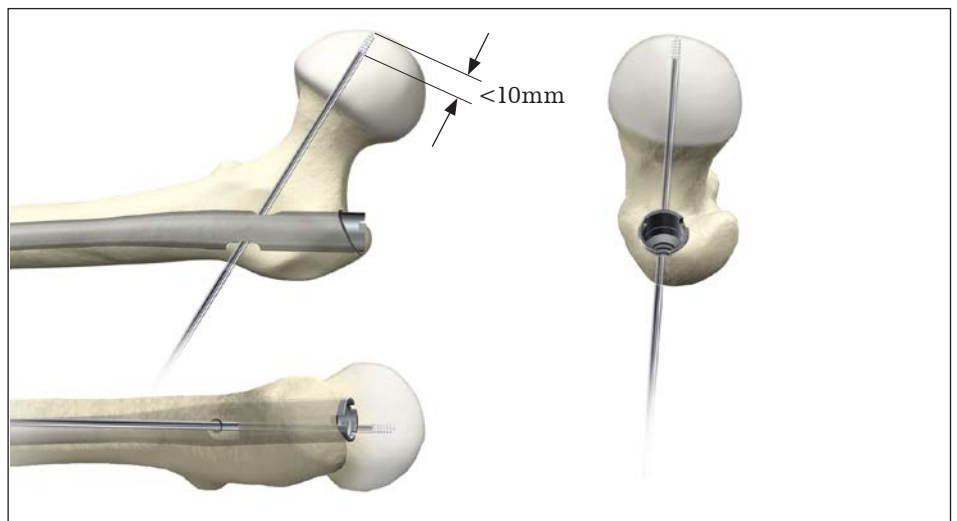

K-wire placement

Fig. 69

Operative technique

Fragment control clip

The fragment control clip may help to provide temporary rotational fixation of the femoral head fragment during reaming and lag screw insertion.

Assembly

Assemble the fragment control clip, with the open lever arm onto the inserted lag screw guide sleeve and then onto the target device (Fig. 70). A snap is felt if the fragment control clip is placed correctly onto the lag screw guide sleeve.

Make sure that the fragment control clip is positioned in close contact to the target device (Fig. 71).

Close the lever arm completely to stabilize the fragment control clip. Resistance is felt if the lever arm is in its final position.

Inserting the fragment control sleeve

Advance the fragment control sleeve through the appropriate hole (typically anterior) of the fragment control clip. The anterior safety clamp of the fragment control clip should be pressed down during this procedure to allow free sliding of the sleeve. The safety clamp is designed to keep the fragment control sleeve in position.

Pushing the fragment control sleeve to the level of the skin, may indicate the site for a small incision down to the bone.

The fragment control sleeve is now advanced through the incision (Fig. 71). If the fragment control sleeve catches the fascia lata, twisting will usually allow it to pass to the bone.

In order to open the lateral cortex by drilling, the fragment control sleeve must be in contact with the lateral cortex of the femur (Fig. 72).

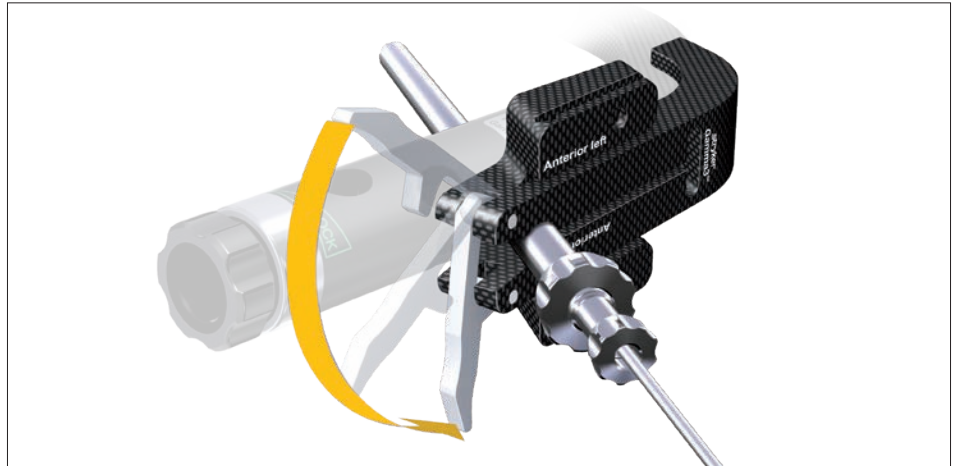

Fig. 70

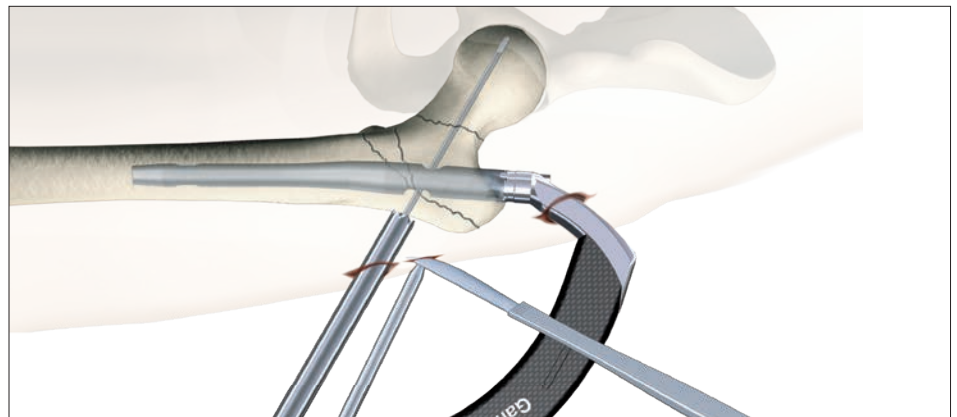

Fig. 71

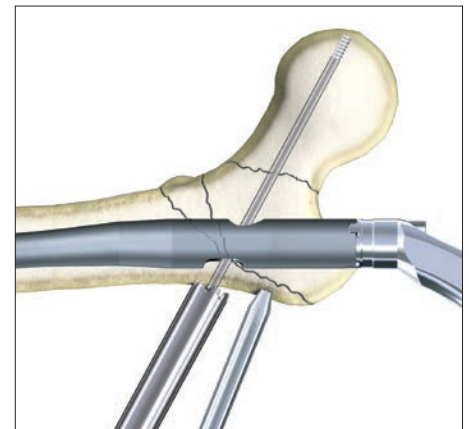

Fig. 72

Operative technique

Using the white coded center tipped drill 3.0mm × 300mm, the lateral cortex should be carefully opened by using a power tool (Fig. 73).

K-wire placement

The drill is then replaced by the 3.2mm × 450mm k-wire. Using the guide wire handle, the k-wire should be placed as close as possible to the subchondral bone of the femoral head. This allows for maximum stabilization of the head-neck fragment (Fig. 74). For lag screw insertion, refer to section 'Lag screw insertion' below.

Removal of fragment control clip

By using the guide wire handle, the k-wire of the fragment control clip must be removed after lag screw fixation.

Remove the fragment control sleeve by pressing the safety clamp down and then remove the fragment control clip by opening the lever arm.

⚠ CAUTION

The fragment control clip should only be used if the diameter of the femoral neck allows k-wire insertion without penetrating the cortex of the femoral neck, to avoid damaging the circumflex artery.

It is strongly recommended to use the anterior approach of the fragment control clip only. A posterior insertion of the k-wire could cause injury of the circumflex artery at the dorsal portion of the trochanteric region.

If the fixation of the fragment control clip on the target device and lag screw guide sleeve is not properly done, a dislocation of the k-wire may cause injuries.

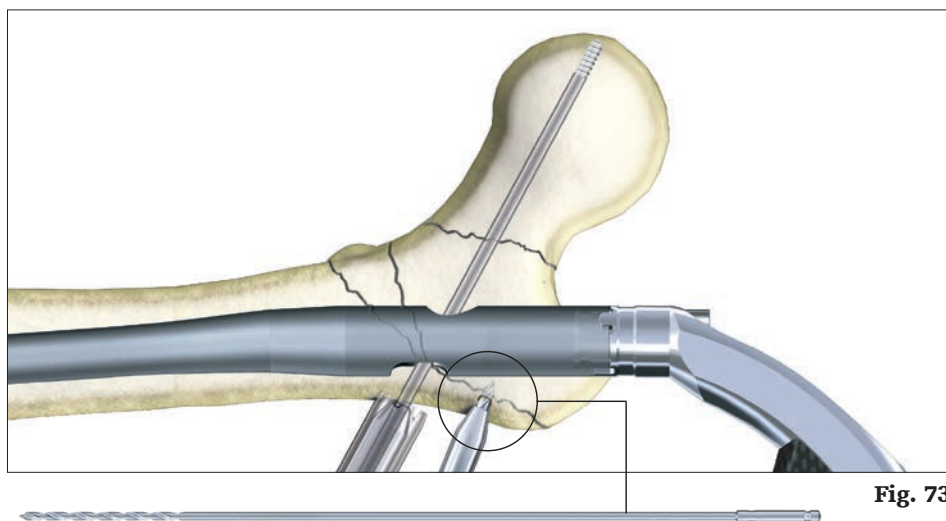

Fig. 73

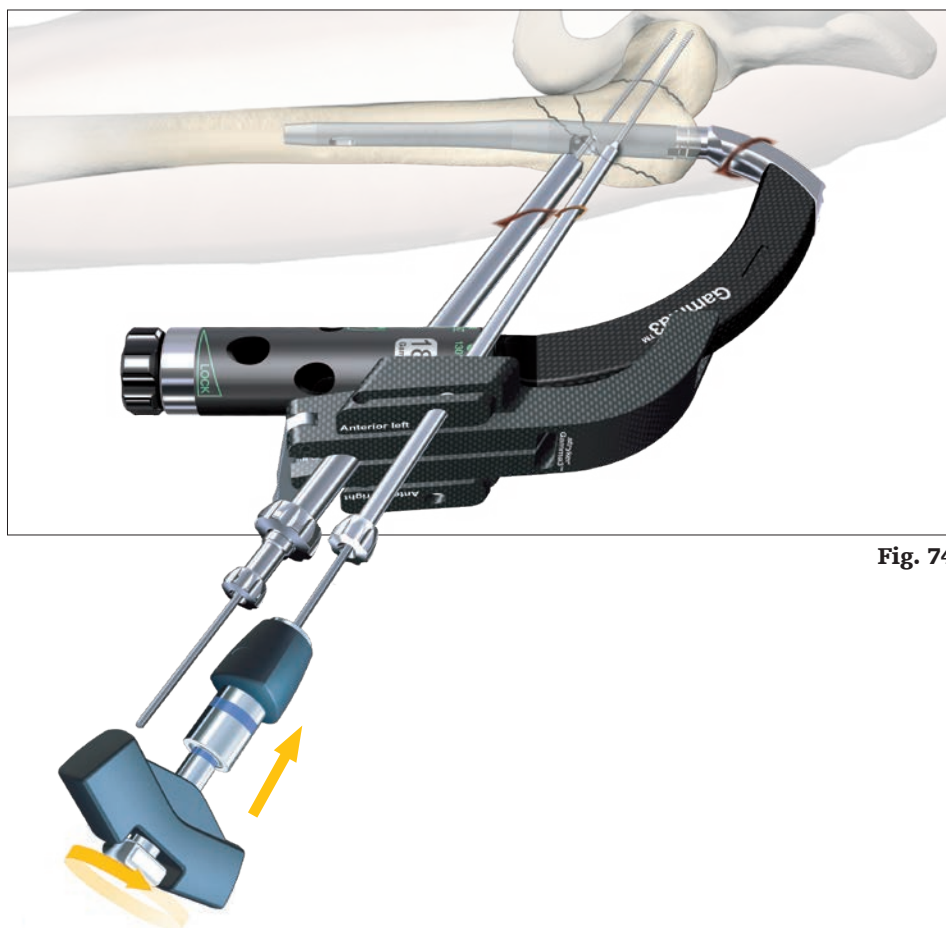

Fig. 74

Operative technique

Lag screw insertion and placement

After satisfactorily positioning the k-wire center or slightly inferior in the A-P and centrally in the lateral view, the required lag screw length is measured using the lag screw ruler. Stryker's ADAPT for Gamma3 system may be used to aid in lag screw length determination.

For accurate length measurement, ensure that the lag screw guide sleeve is still pressed firmly against the lateral cortex of the femur (Fig 75, Fig. 76).

Place the lag screw ruler directly under the k-wire (Fig. 77a). As shown on the lag screw ruler, the ruler deducts the 10mm thread from the tip of the k-wire for measurement (Fig. 77b). To obtain an accurate measurement, the k-wire should be placed to subchondral bone.

The recommended value for the step drill depth and the lag screw length can be read directly from the lag screw ruler or by using Stryker's ADAPT for Gamma3 system. With the k-wire in the subchondral bone, if the value is between markings on the scale, e.g. 97mm, it should always be rounded up to the next higher value, e.g. 100mm (Fig. 77a). If compression/apposition is required, make sure to take the fracture gap into account as this will affect the measurement. To perform compression/apposition, refer to section 'Compression / apposition' below. If not taken into account, the lag screw may cause soft tissue irritation around the lateral cortex.

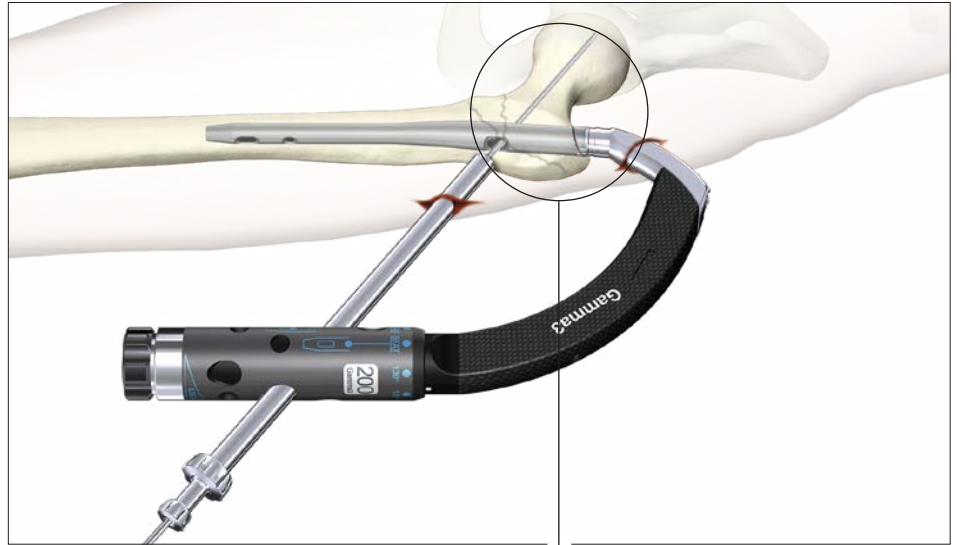

Fig. 75

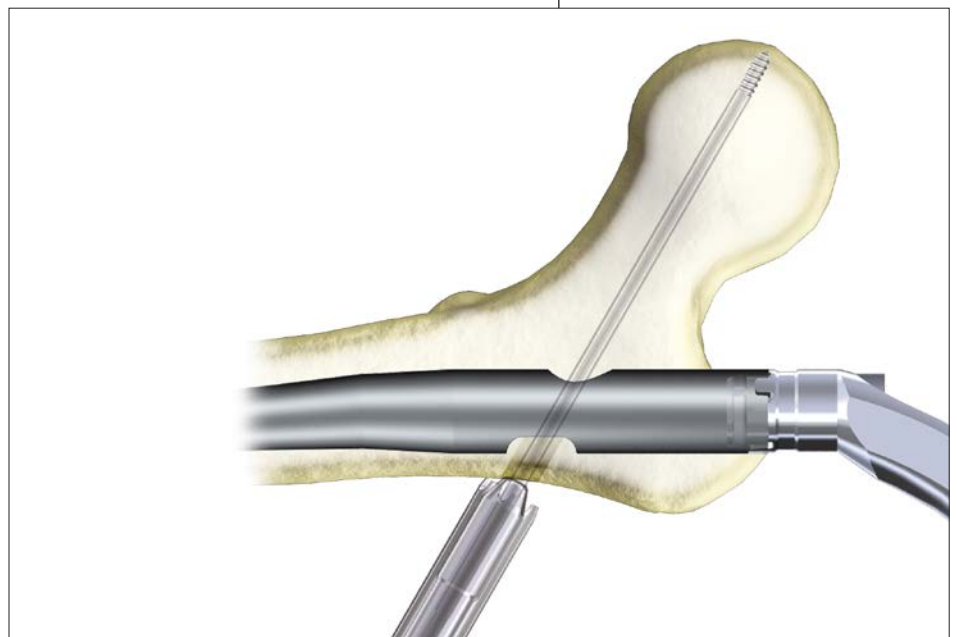

Fig. 76

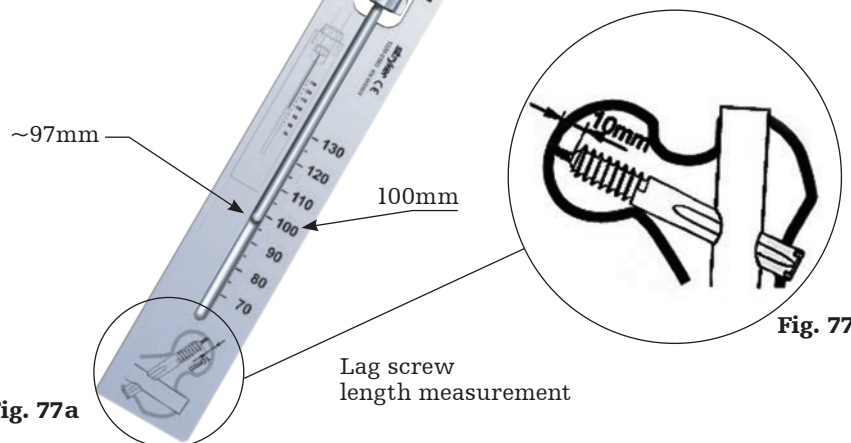

Fig. 77a

Fig. 77b

Operative technique

The value of the measurement is now transferred to the adjustable stop on the lag screw step drill (Fig. 78). The value (e.g. 100) must be visible in the window (Fig. 79).

The k-wire sleeve is now removed and the adjusted lag screw step drill is passed over the k-wire, through the lag screw guide sleeve (Fig. 80).

The channel for the lag screw is prepared using the t-handle connected to the lag screw step drill. A power tool may be used with great care paying special attention to the k-wire position.

Drilling should continue until the stop of the step drill comes into contact with the lag screw guide sleeve (Fig. 80a). Ensure that the target device is well supported to prevent it from slipping back or rotating.

The drilling process, especially when the tip of the drill comes close to its final position in the femoral head, should be controlled under an image intensifier to avoid hip joint penetration. The k-wire also may be observed in the k-wire window of the step drill (Fig. 80b).

⚠ WARNING

It is important to observe the k-wire tip during drilling on the image intensifier. The k-wire window provides an additional method to check the k-wire end position.

Avoid hip joint penetration and ensure that under no circumstances the k-wire is advanced into the pelvis. In case a deflection of the k-wire is observed, it is strongly recommended to remove the k-wire and replace it with a new one. If the step drill does not pass through the lag screw hole with ease, check by image intensifier whether the k-wire is deflected or not.

Never drive the step drill with force through the nail, since this may cause severe damage to the nail resulting in increased risk of implant failure.



Fig. 78

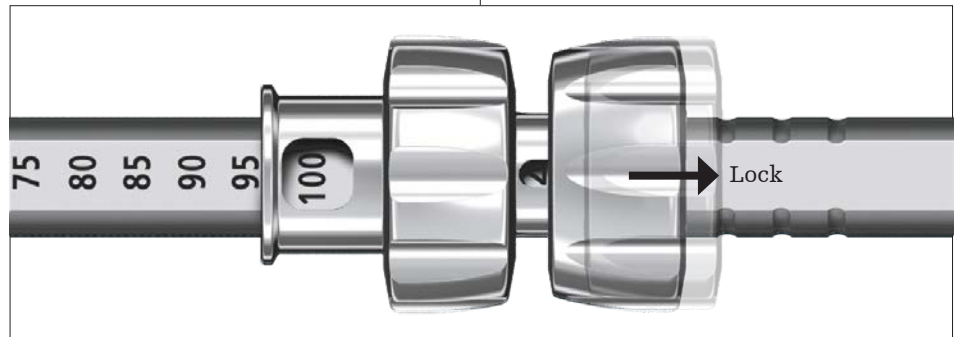

Fig. 79

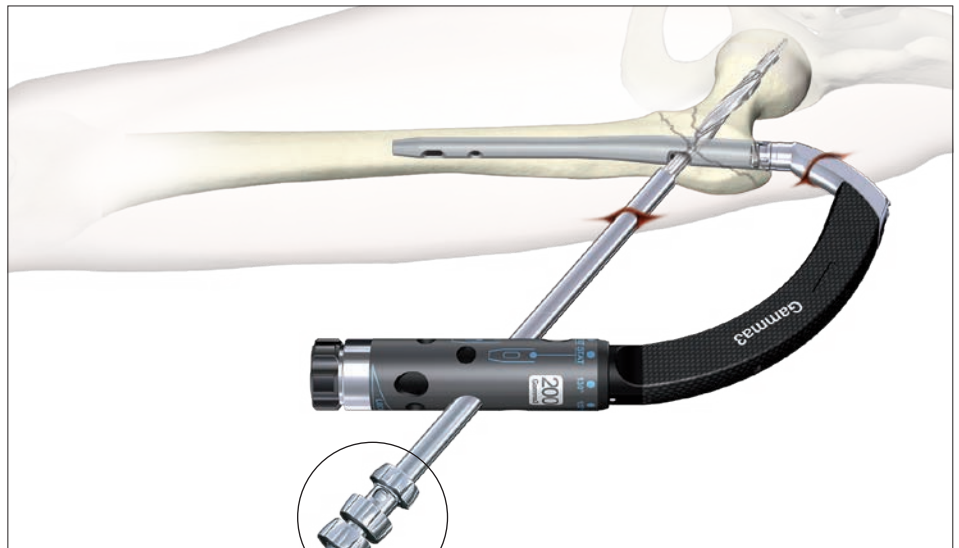

Fig. 80

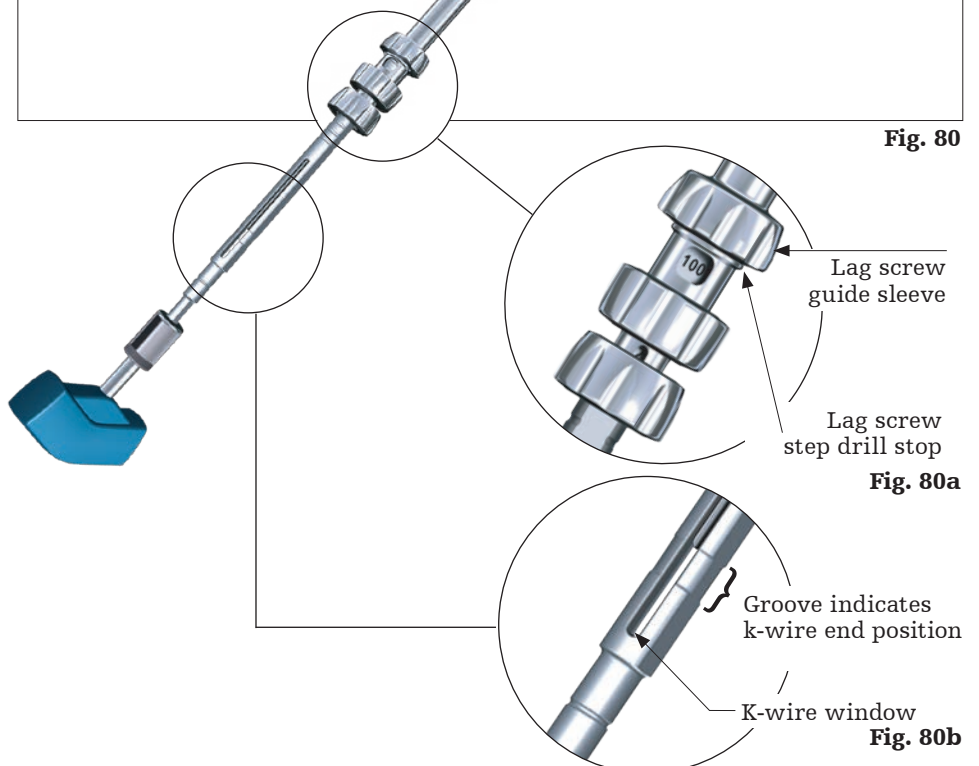

Fig. 80a

Fig. 80b

Operative technique

Check on the image intensifier during drilling to monitor the depth of the drill near the subchondral bone.

After reaching the step drill stop, you should see the tip of the k-wire protruding about 6 to 10mm out of the step drill (Fig. 81). This is because the threaded portion of the k-wire was intentionally not included in the length measurement in order to ensure that the k-wire remains anchored in the subchondral bone after reaming. Now you may remove the step drill.

If extremely strong bone is encountered, the lag screw tap may be used to allow for easier insertion (Fig. 82).

The selected length of the step drill, the lag screw tap and the lag screw should all be the same (in this example 100mm).

The lag screw is then assembled to the lag screwdriver (Fig. 83).

Ensure that the pins of the lag screwdriver are in the slots of the lag screw. The end thumbwheel must be turned clockwise and tightened.

The lag screw assembly is now passed over the k-wire, through the lag screw guide sleeve, and threaded up to the end of the pre-drilled hole of the femoral head. Check the end position of the lag screw on the image intensifier. A double check of the end position is also possible with the indicator ring (Fig. 83a) on the lag screwdriver when it reaches the end of the lag screw guide sleeve.

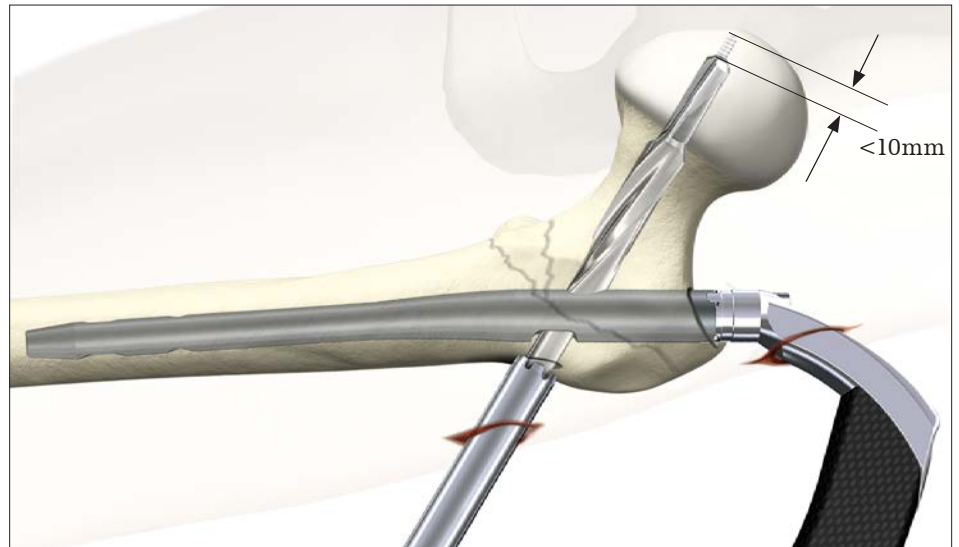

Fig. 81



Fig. 82

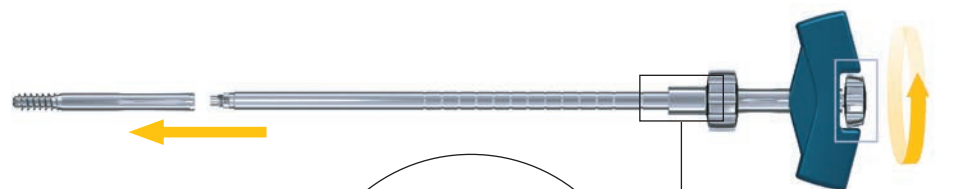

Fig. 83

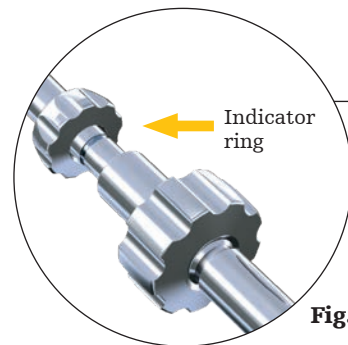

Fig. 83a

⚠ WARNING

Make sure that the k-wire does not protrude into the pelvis during step drill and lag screw insertion.

Operative technique

Lag screw fixation

The handle of the lag screwdriver must be parallel or perpendicular (90°) to the target device to ensure that the set screw is able to fit into one of the four grooves on the lag screw shaft. The set screw alignment indicator will help to find the correct position of the handle. Refer to Fig. 84.

If the t-handle is not perpendicular or parallel to the target device, turn it clockwise until it reaches this position. Do not turn the lag screw counterclockwise during insertion.

⚠ WARNING

It is strongly recommended to place the lag screw at the end of the pre-drilled hole in order to provide maximal resistance against cut-out. Never turn the lag screw counterclockwise after the final position is reached, otherwise the lag screw may lose full bony surface contact to its tip.

Compression / apposition

If compression or apposition of the fracture gap is required, this can be achieved by gently turning the thumb-wheel of the lag screwdriver clockwise against the lag screw guide sleeve (Fig. 85).

To prevent migration of the lag screw guide sleeve, ensure that the speedlock sleeve knob is in the locked position.

⚠ CAUTION

In osteoporotic bone care must be taken to prevent lag screw pullout in the femoral head. The lag screw should be chosen shorter depending on the expected amount of compression.

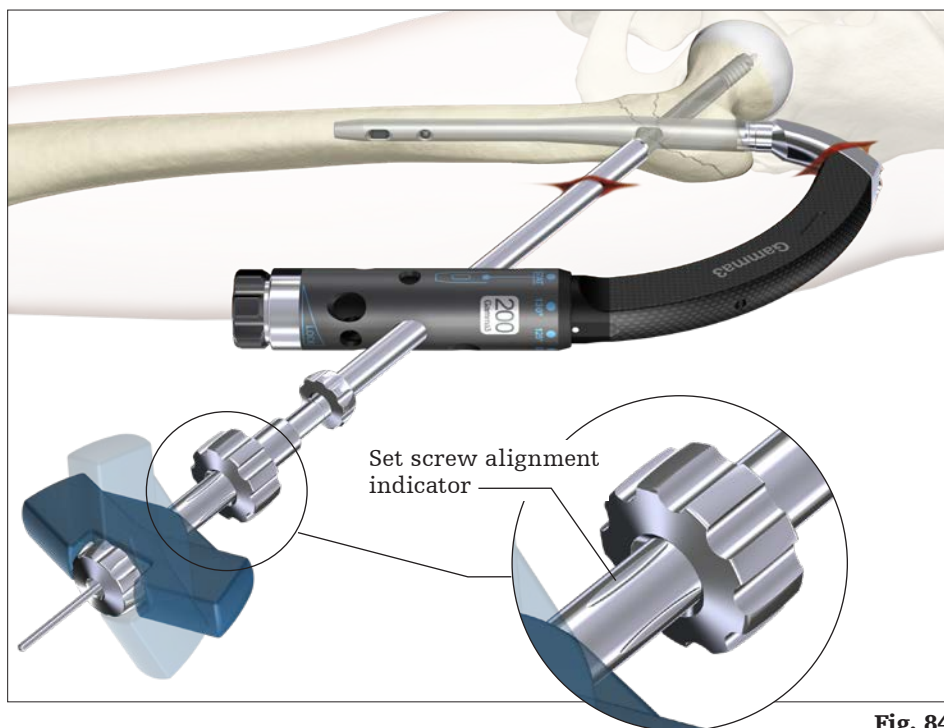

Fig. 84

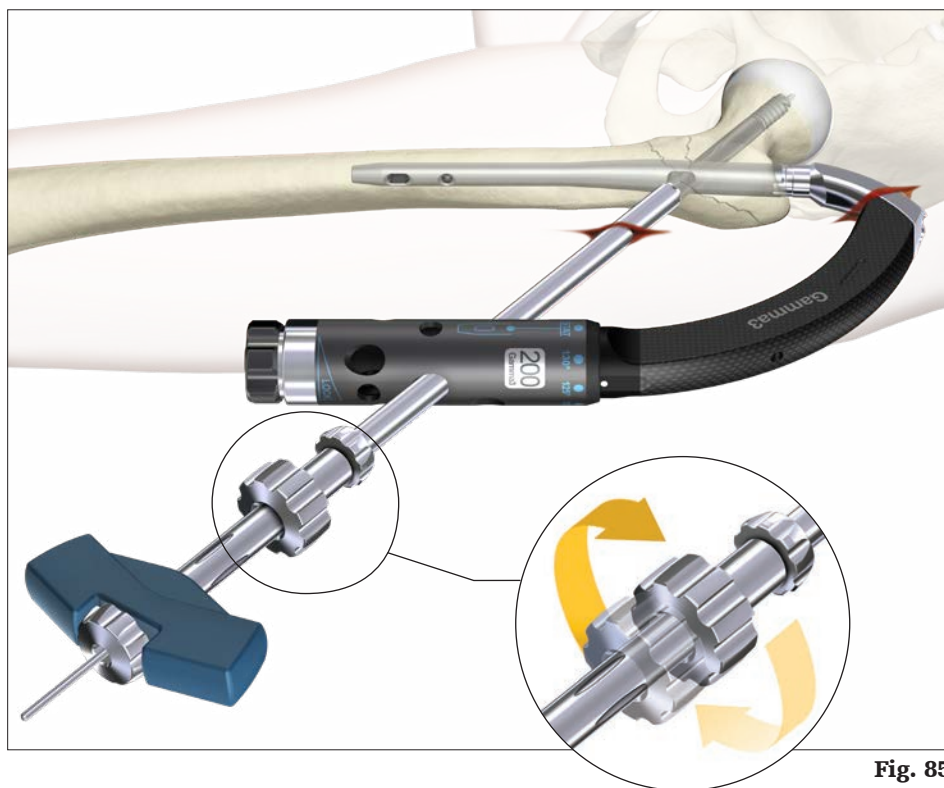

Fig. 85

Operative technique

U-blade lag screw

If additional rotational stability and fixation performance is desired, the u-blade lag screw may be used as an option.

The u-blade lag screw set is delivered pre-assembled in the packaging. Separate the set by removing the end cap.

U-blade lag screw insertion

Attach the u-blade lag screw to the u-blade lag screwdriver (the Gamma3 U-Blade Lag Screw can not be connected to the regular Gamma3 Lag Screwdriver) and tighten the thumbwheel. The u-blade lag screw assembly is now passed over the k-wire, through the lag screw guide sleeve, and placed in the desired position within the femoral head under X-ray visualization. A double check of the end position is also possible with the indicator ring on the u-blade lag screwdriver when it reaches the end of the lag screw guide sleeve (Fig. 86). The design of the u-blade lag screw provides two set screw grooves (standard lag screw provides four). For correct lag screw alignment, the set screw alignment indicator will help to find the correct position of the handle (Fig. 87).

If compression or apposition of the fracture gap is required, refer to the section 'Compression/apposition' above.

⚠ WARNING

The handle must be perpendicular to the target device, when the u-blade lag screw is in the final position (Fig. 87).



Fig. 86



Fig. 87

Operative technique

U-blade insertion

Before inserting the u-blade, disconnect the u-blade lag screwdriver from the u-blade lag screw by turning the thumbwheel counterclockwise. Remove the u-blade lag screwdriver and the k-wire.

Attach the t-handle to the u-blade lag screw connector (Fig. 88) and pass the assembly through the lag screw guide sleeve (Fig. 89). Turn the T-handle clockwise. Turning stops when the u-blade lag screw has reached its end position. Remove the t-handle from u-blade lag screw connector.

Now connect the u-blade to the u-blade connector by turning the u-blade connector clockwise (Fig. 90).

Push the u-blade assembly gently over the u-blade lag screw connector (Fig. 91) and into the flutes of the u-blade lag screw.

The insertion is done by hand until the u-blade spreads open and starts to contact the surrounding bone. At this point, the u-blade should be approximately 25mm away from its final position. Refer to Fig. 92.

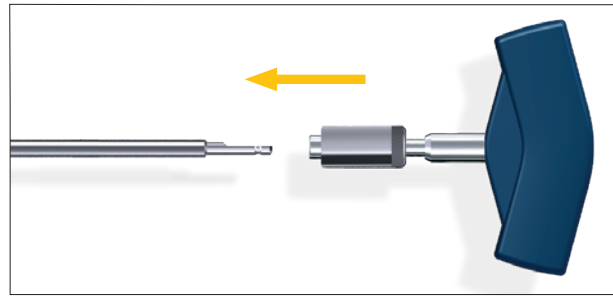

Fig. 88

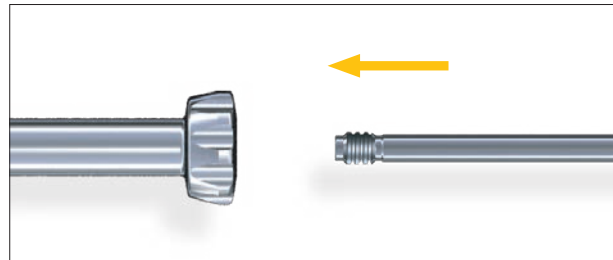

Fig. 89



Fig. 90



Fig. 91

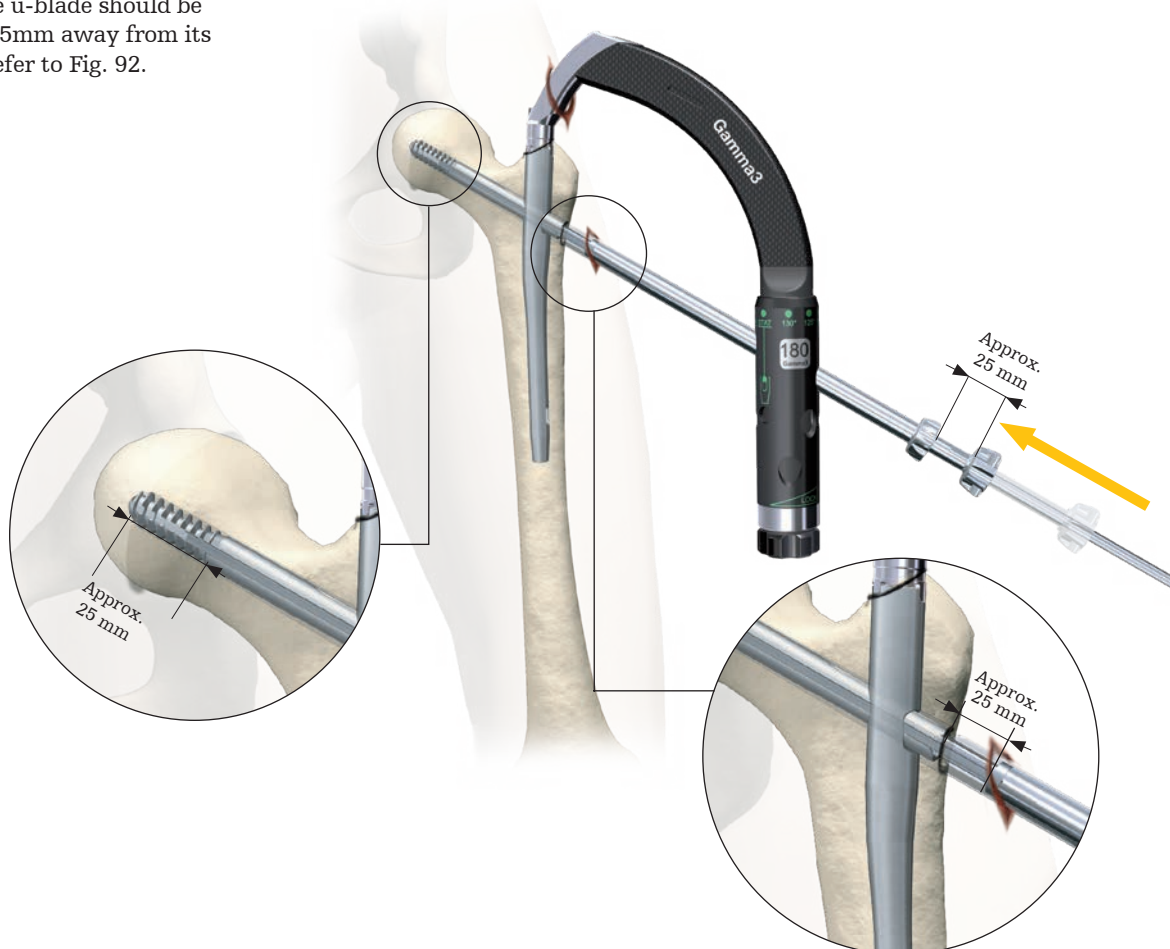

Fig. 92

Operative technique

The Gamma3 U-Blade Inserter is required to move the u-blade into its final position (Fig. 93).

⚠ CAUTION
Never use a hammer.

Position the u-blade inserter over the u-blade connector until it contacts the u-blade connector.

Push the inserter and press the lever to move the u-blade forward. The u-blade inserter stops mechanically when the u-blade has been inserted completely.

The final position of the u-blade is indicated when the peg of the u-blade inserter is in line with the indicator ring on the u-blade lag screw connector (Fig. 93).

A visual check with the image intensifier in the lateral view is recommended to confirm the u-blade's final position.

Remove the u-blade inserter, u-blade connector and u-blade lag screw connector.

End cap insertion

Insert the end cap through the lag screw guide sleeve using the straight screwdriver and tighten firmly (Fig. 94). Remove the screwdriver and the lag screw guide sleeve (Fig. 95).

NOTICE
Fixation of the u-blade is always completed by securely fastening the end cap into the u-blade lag screw.

⚠ CAUTION
If the Gamma3 U-Blade Lag Screw is not correctly secured with the set screw, rotational stability of the head fragment cannot be assured.

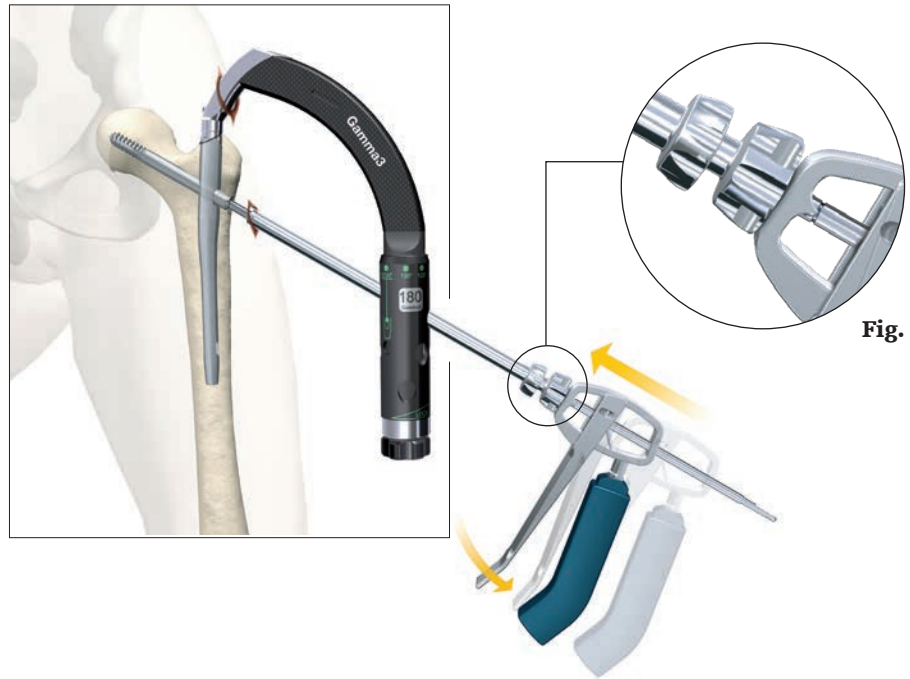

Fig. 93



Fig. 94



Fig. 95

Operative technique

Set screw insertion

WARNING

The set screw must be used.

Assemble the set screw to either the straight or flexible set screwdriver (Fig. 96).

Insert the set screw along the opening of the post of the target device and advance it through the nail holding screw by pushing the set screwdriver (Fig. 97).

If using the Gamma3 Plus Target Device (Fig. 98), make sure to use the corresponding set screwdriver for insertion.

Push the set screw driver down until the set screw engages with the corresponding thread in the nail. While inserting the set screw, you may feel slight resistance.

Turn the screwdriver handle clockwise under continuous pressure. You may notice a resistance when turning the set screw. This is because the set screw thread is equipped with a self-retaining feature to prevent spontaneous loosening.

Keep turning the set screw until you feel contact in one of the grooves of the lag screw (Fig. 99).

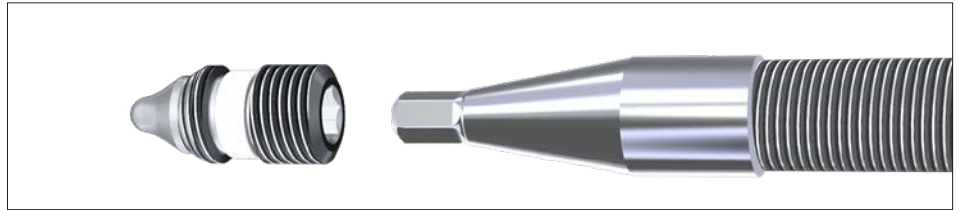

Fig. 96



Fig. 97



Fig. 98

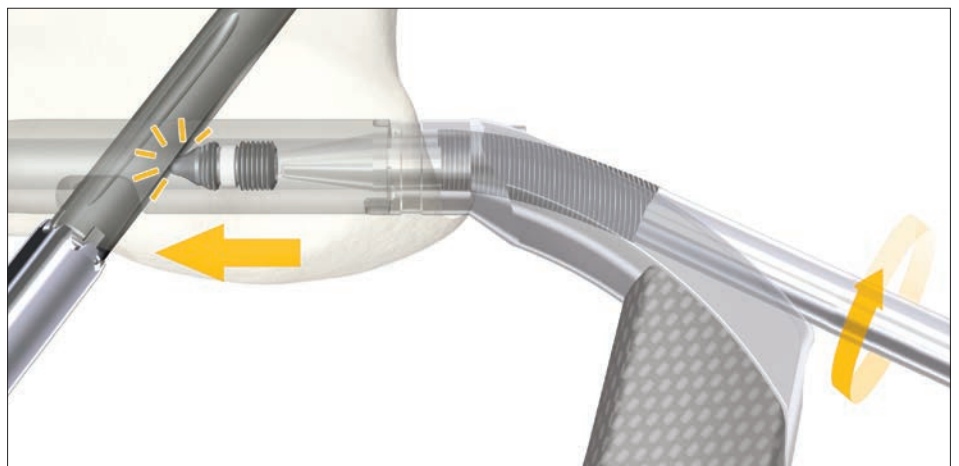

Fig. 99

Operative technique

Set screw fixation

To verify the correct position of the set screw, try to turn the lag screwdriver (Fig. 100). It is not possible to turn the lag screwdriver if the set screw is engaged with the lag screw groove. If the lag screw driver still moves, recorrect the handle position and tighten the set screw again until it engages in one of the four grooves (Fig. 101).

After tightening the set screw, unscrew the set screw by no more than a quarter (1/4) of a turn, until a small play can be felt at the lag screwdriver. This ensures free sliding of the lag screw. Refer to Fig. 102.

Make sure that the set screw is still engaged in the groove by checking that it is still not possible to turn the lag screw with the lag screwdriver.

⚠ WARNING

Do not unscrew the set screw more than 1/4 of a turn. Insufficient contact between lag screw and set screw could lead to loss of fixation and implant failure.

Remove the lag screwdriver, k-wire and lag screw guide sleeve.

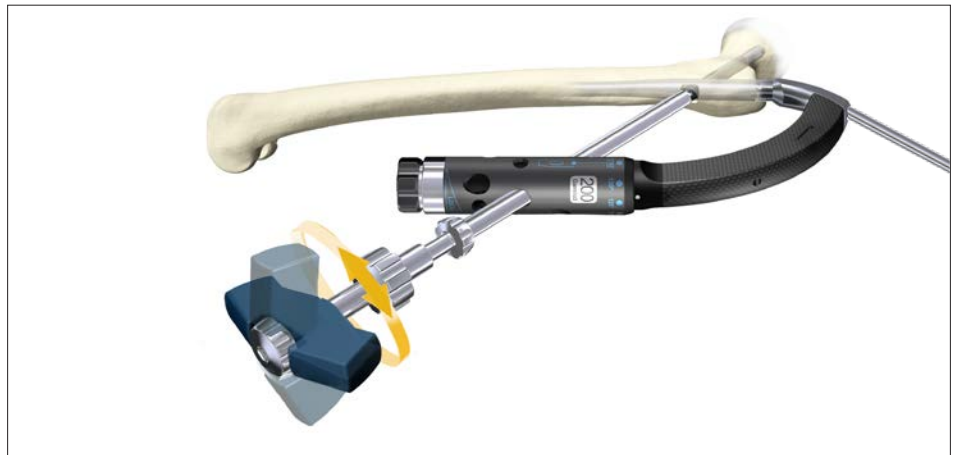

Fig. 100

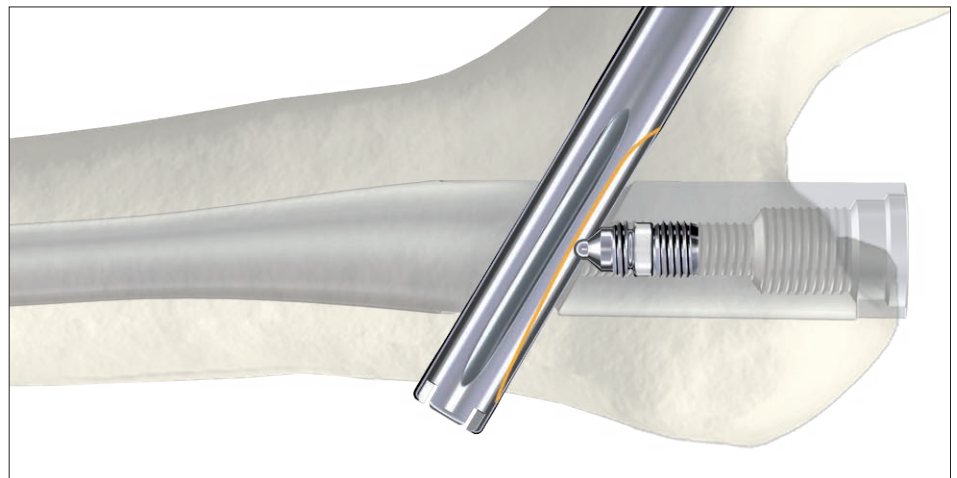

Fig. 101

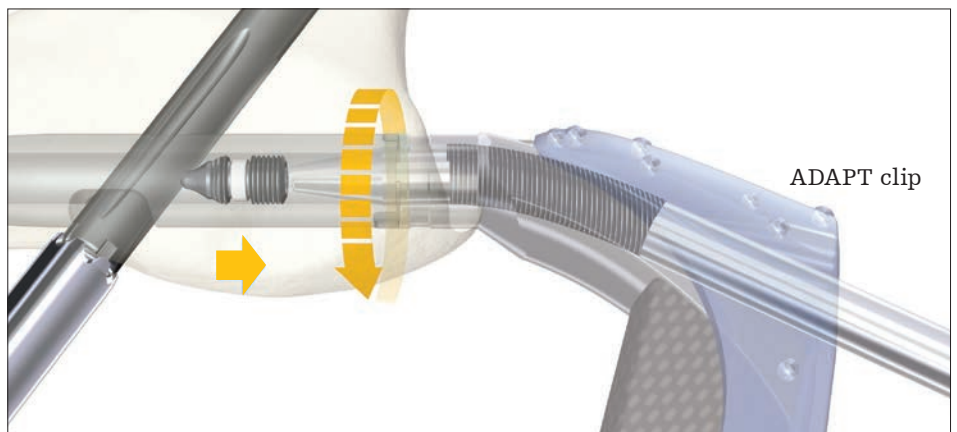

Fig. 102

Operative technique

Alternative: Set screw insertion with Gamma3 Closed Tube & ADAPT Clip

The closed tube and ADAPT clip's are designed to create a guided path for the flexible set screw driver. These clip's are only compatible with the Gamma3 Target Device, Threaded Post.

It is assembled onto the Gamma3 Target Device by squeezing the flanges together and placing it onto the target device (Fig. 103). Pushing the clip with your thumb (Fig. 104 and Fig. 105) will lock it onto the target device. Insert the set screw according to the normal procedure (Fig. 106).

⚠ CAUTION

The Gamma3 Closed Tube Clip and ADAPT Clip is designed for the flexible set screwdriver only and not for the straight set screwdriver.



Fig. 103



Fig. 104



Fig. 105



Fig. 106

Operative technique

Distal targeting system

The distal targeting system (DTS) is designed for guided distal locking of long nails. For a system overview, refer to section 'Design - Distal targeting system'.

⚠ CAUTION

Distal targeting system R2.0 version is designed for Gamma3 Long Nails R2.0 or T2 Recon nails R2.0. Make sure to have the R2.0 nails prior to the surgery.

Distal targeting system R1.5 version is designed for Gamma3 Long Nails R1.5 or T2 Recon Nails R1.5. Make sure to have the R1.5 nails prior to the surgery.

Distal locking options

The appropriate adjusting device should be selected according to the locking mode.

- Static locking**
 If the locking configuration is static/static (Fig. 107), select the adjusting device left static (Fig. 108) or right static (Fig. 109) for the appropriate treatment side.
- Dynamic or static/dynamic locking**
 For static/dynamic locking for both left and right sides (Fig. 110, Fig. 111), the adjusting device left/right dynamic is available (Fig. 112).

Pre-operative functional check and assembly

A check is recommended after nail length determination and prior to nail insertion. In order to do so, assemble the distal targeting system as described in the following.

Align the white dots and slide the distal targeting device onto the Gamma3 Target Device until a click is felt. The white line must be seen through the alignment indicator window for correct assembly (Fig. 113). Insert the fixation bolt completely through the lateral

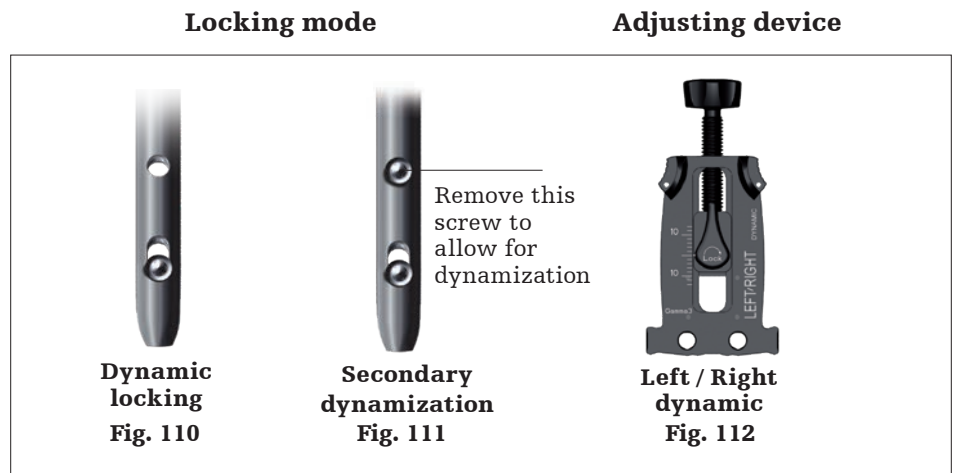
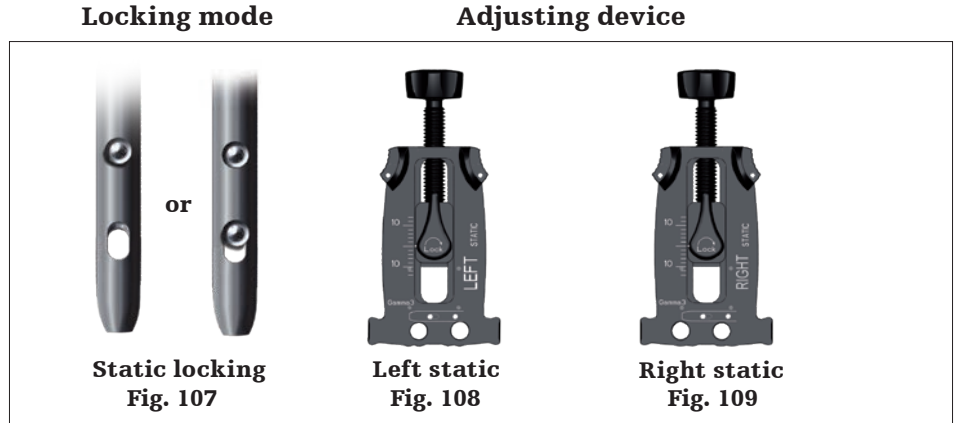

Fig. 113



Fig. 114

opening until a click is felt. The fixation lever must then be securely locked. Refer to Fig. 114.

⚠ CAUTION

Ensure that the distal targeting arm is positioned anteriorly to the chosen nail (Fig. 115).

Operative technique

The length of the chosen nail determines where the adjusting device should be attached. The selected adjusting device is placed into the pin positioning holes that match the length of the selected nail. The corresponding nail lengths are marked on the distal targeting device (Fig. 116).



Fig. 115

CAUTION
 Be certain that both positioning pins are placed into the pin positioning holes and securely locked with the adjusting device lever.

Lock the adjusting device lever by turning it in a clockwise direction (Fig. 117, Fig. 118).

Insert the tissue protection sleeve into the proximal targeting hole of the adjusting device by pressing the sleeve fixation button on the adjusting device (Fig. 119). The sleeve moves freely when the button is pressed.

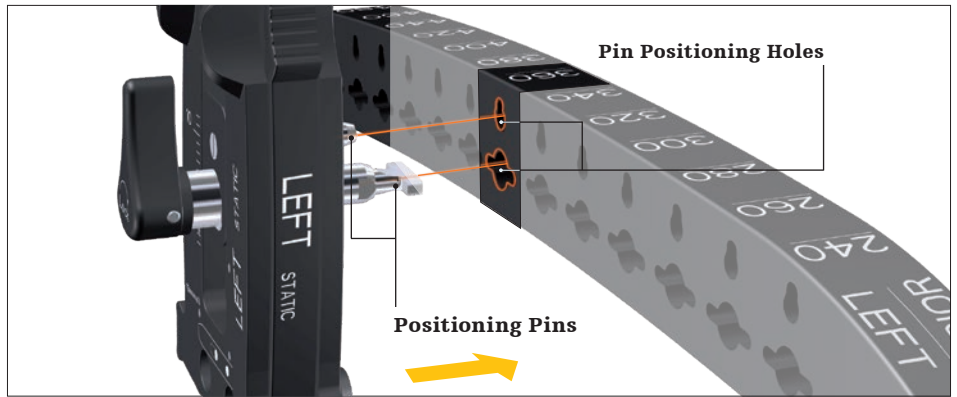

Fig. 116



Fig. 117

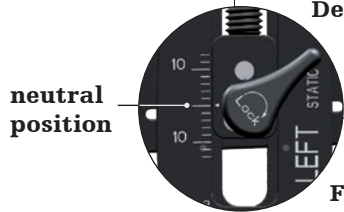

Fig. 118

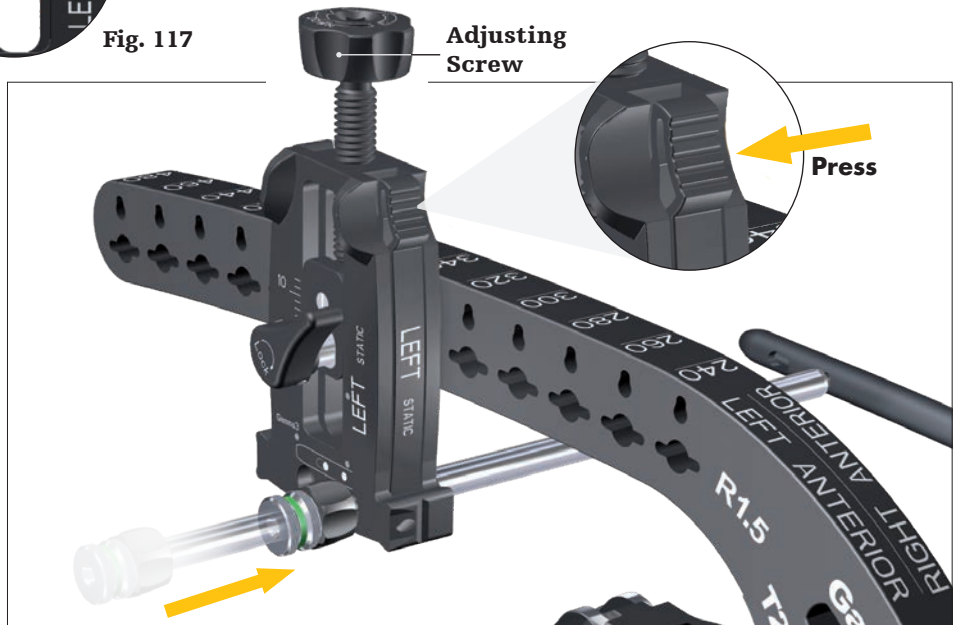

Fig. 119

Operative technique

A-P adjustment

The distal targeting tray has a dedicated calibration stand. Place the assembled device onto this by placing it onto the metal pin (Fig. 122, Fig. 123).

Look through the tissue protection sleeve and adjust the targeting position by turning the adjusting screw until the holes of the sleeve and the nail appear coaxial. Alternatively, the drill sleeve may be assembled into the tissue protection sleeve and the drill may be used for accurate adjustment (Fig. 120, Fig. 121).

The pre-operative functional check can be performed with and without the stand. In order to stabilize the T2 Recon Nails for calibration, the adapter for DTS calibration is available as an option. Please check with your local Stryker representative regarding availability.

After the calibration steps have been completed, remove the sleeve assembly by pressing the sleeve fixation button on the adjusting device (Fig. 124). Release the fixation lever, then remove the fixation bolt (Fig. 125) and place it into the fixation bolt storage pocket (Fig. 126).

Detach the distal targeting device assembly and place it back into the distal targeting system tray (Fig. 127, Fig. 128).

After preparation of the distal targeting system, continue with the surgery (refer to section 'Assembly of proximal target device and implant').

⚠ CAUTION

Prior to the insertion of the nail, make sure that reaming has been completed according to the Gamma3 operative technique. With proper reaming, the nail should enter the canal with little resistance. This may help to avoid possible deformation of the nail.

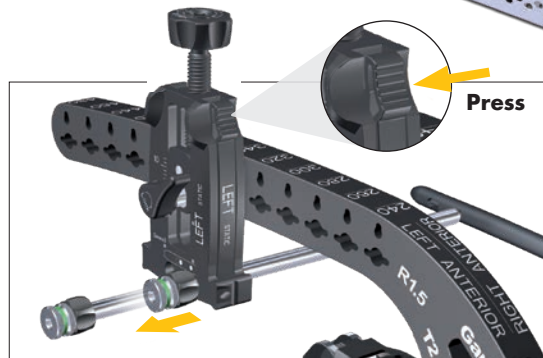
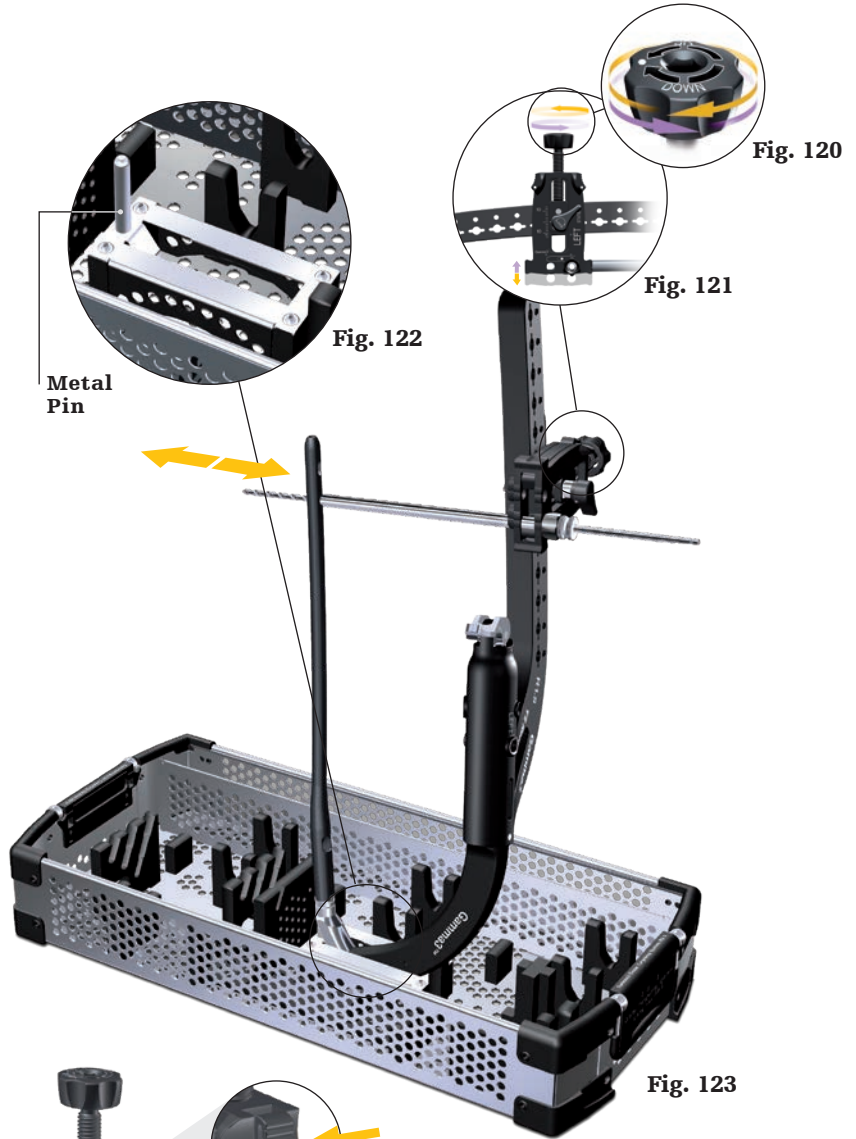

Fig. 124

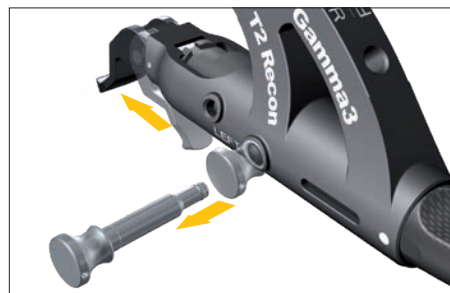

Fig. 125



Fig. 126

Operative technique

⚠ CAUTION

Keep the adjusting device in its position as calibrated. Do not remove the adjusting device from the distal targeting device at this point.

If the nail holding screw is not securely tightened, the distal locking function may not work appropriately.

Distal locking

The distal targeting device is assembled to the target device as described in section 'Pre-operative functional check and assembly'. The white dots are aligned and the white line must be visible in the alignment indicator window (Fig. 129). The distal targeting device must be pushed all the way in until an audible click is heard. The fixation bolt is removed from the fixation bolt storage pocket and reinserted through the lateral opening in white, going completely through the target device until a click is felt. Then, the fixation lever must be locked to ensure proper fixation. This is required to secure the distal targeting device to the target device and stabilize the system. Refer to Fig. 130.

⚠ CAUTION

Ensure that the distal targeting arm is positioned anteriorly to the chosen nail (Fig. 129).

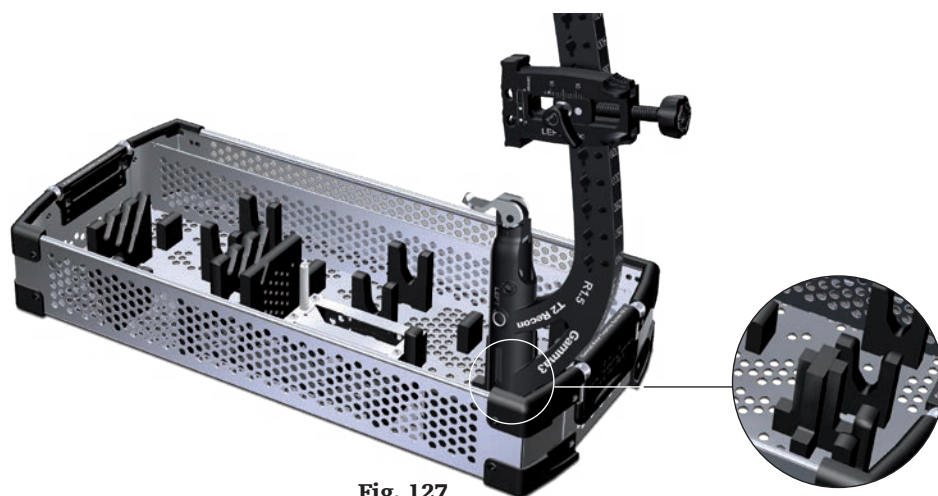

Fig. 127

Fig. 128

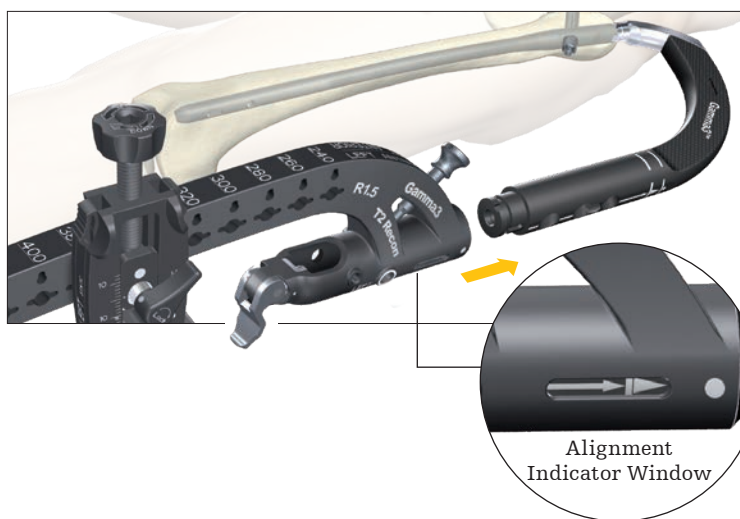

Fig. 129



Fig. 130

Operative technique

Assemble the tissue protection sleeve, drill sleeve and trocar. Press the sleeve fixation button of the adjusting device (Fig. 132a) and insert the assembled sleeves through the distal targeting hole. Advance the assembly close to the skin (Fig. 131), but make sure not to touch the skin with the tip of the trocar so that free adjustment in anterior or posterior direction is possible. By releasing the sleeve fixation button, the sleeve assembly is fixed in the desired position.

NOTICE

Do not make a skin incision before the final adjustment of the adjusting device to avoid soft tissue pressure to the sleeve assembly.

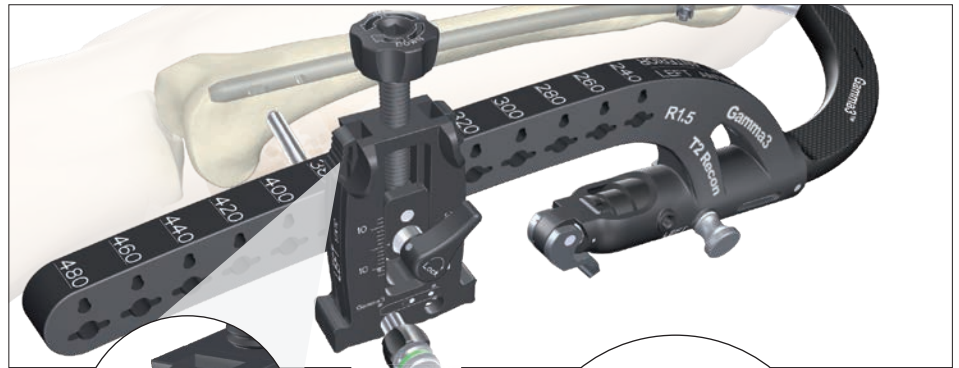

Fig. 131

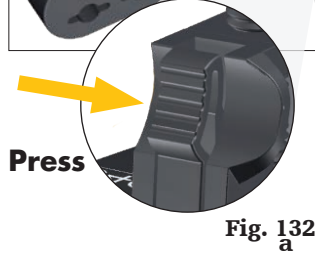

Fig. 132a

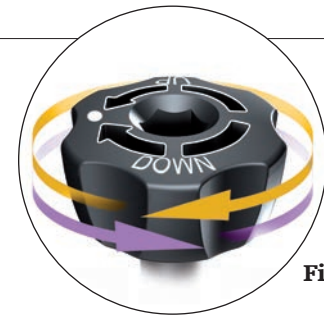

Fig. 132b

In order to achieve the best result of the system, start the guided distal locking procedure from the distal hole. Once the image intensifier is properly positioned, relative to the nail hole geometry, the sleeves can be moved anteriorly (counterclockwise) or posteriorly (clockwise) by turning the adjusting screw (Fig. 132b). It may be turned by hand or by using the ball tip screwdriver.

C-arm positioning

The C-arm should be placed approximately 30 degrees oblique to the axis of the drill sleeve assembly (Fig. 133). The center of the X-ray beam should target the nail tip. Orbital adjustment of the X-ray beam should be parallel to the tissue protection sleeve. As an option, the oblique alignment wire can be inserted from the lateral opening of the adjusting device (Fig. 135). This wire indicates the required axis of the X-ray beam. The goal is to achieve a projection showing the sleeve assembly parallel to the nail tip (Fig. 134).

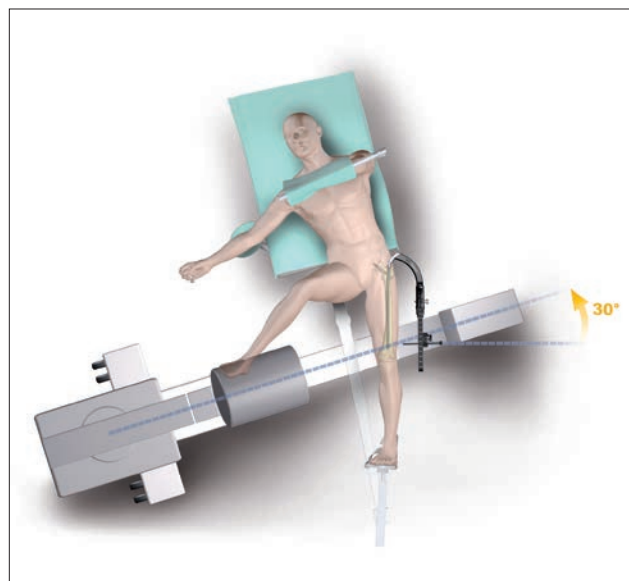

Fig. 133

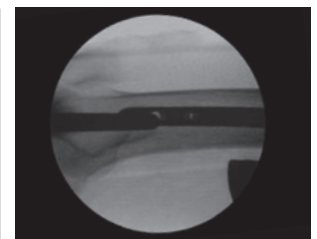

Fig. 134

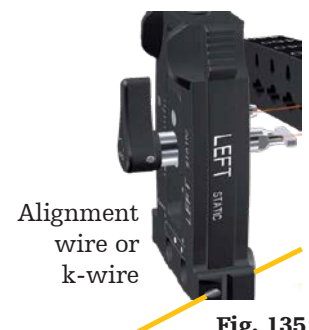

Fig. 135

30 degrees oblique positioning of the C-Arm is an average indication and may need to be readjusted according to the obtained fluoroscopic image. The goal is to achieve a projection showing the nail and the drill sleeve assembly in the center of the fluoroscopic image (Fig. 134). Stryker's ADAPT for Gamma3 system

may be used to aid in c-arm positioning. Contact your Stryker sales representative or refer to the corresponding labeling for more information.

Operative technique

C-arm adjustment

This step requires appropriate C-Arm positioning. Do not turn the adjusting screw until the nail and the sleeve are parallel.

When you see the image shown in Fig. 136 on the image intensifier monitor (tip of sleeve pointing down), adjust the orbital C-Arm position by adjusting the X-ray emitter up in order to project sleeve and nail tip parallel to each other.

When you see the image shown in Fig. 137 on the image intensifier monitor (tip of sleeve pointing up), adjust the orbital C-Arm position by adjusting the X-ray emitter down in order to project sleeve and nail tip parallel to each other. Stryker's ADAPT for Gamma3 system may be used to aid in adjusting the c-arm. Contact your Stryker sales representative or refer to the corresponding labeling for more information.

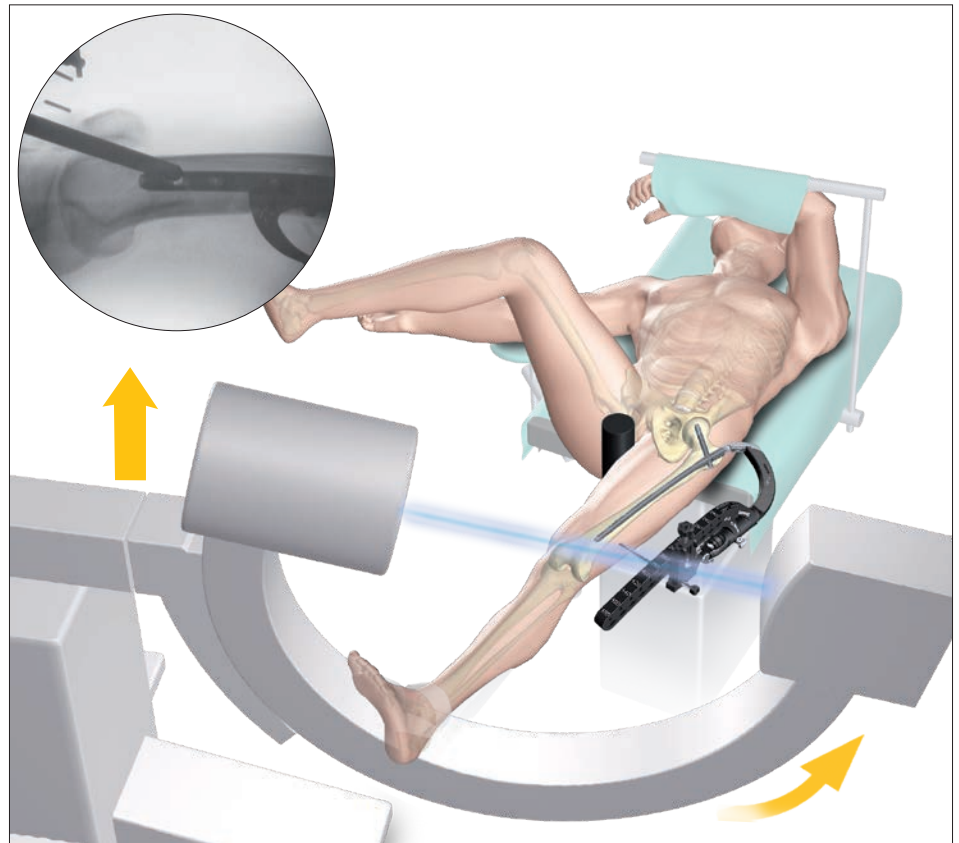

Fig. 136

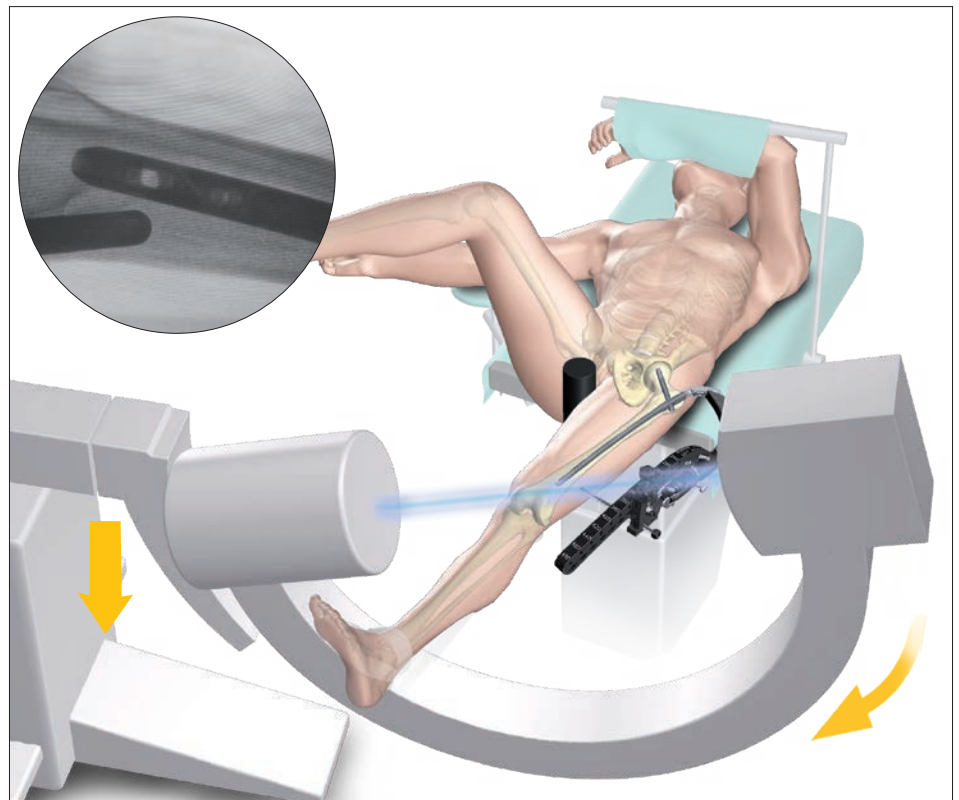

Fig. 137

Operative technique

Sleeve adjustment

Once the C-Arm has been adjusted so that nail and sleeve are shown parallel (Fig. 138), the next step is to have the projections appear collinear. (Fig. 139) This is accomplished by turning the adjusting screw clockwise (sleeve projection goes down, Fig. 138) or counterclockwise (sleeve projection goes up, Fig. 140). Styker's ADAPT for Gamma3 system may be used to aid in nail-sleeve alignment. Contact your Stryker sales representative or refer to the corresponding labeling for more information.

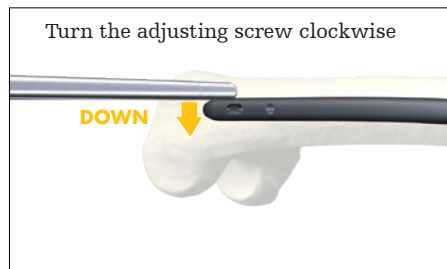

Fig. 138

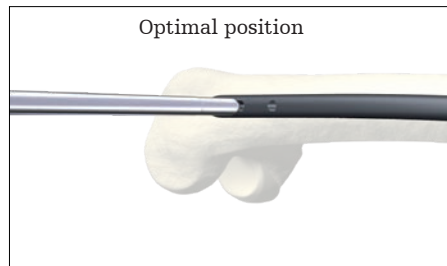

Fig. 139

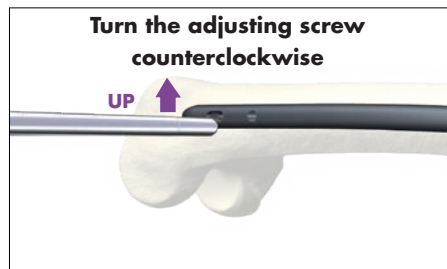

Fig. 140

⚠ CAUTION

Maximum adjustments of ± 14 mm are possible from neutral position. As for the nail lengths 260 and 280mm, the adjustment amounts for posterior direction (down) are limited mechanically. In rare cases when the required adjustment exceeds these limits, an alternative distal locking method should be considered.

Drilling and locking

Once the correct nail and sleeve alignment has been obtained (Fig. 139), the trocar may be used to dimple the skin where a small incision can be made (Fig. 141). Ensure that the incision is down to the lateral cortex and parallel to the sleeve. Press the sleeve fixation button (Fig. 142a) so that the tissue protection sleeve can advance freely.

The head of the trocar will rise a few millimeters above the sleeve when the assembly has been pushed to the lateral cortex. The tip of the tissue protection sleeve should be close to the bone (Fig. 142b).

⚠ CAUTION

Make sure not to push the sleeve assembly too hard in order to avoid the possible slippage of the tip of the sleeve on the curved bone surface.

Take another X-ray shot to confirm that the targeting position is still accurate. If not, readjust as described in section 'Sleeve adjustment' above.

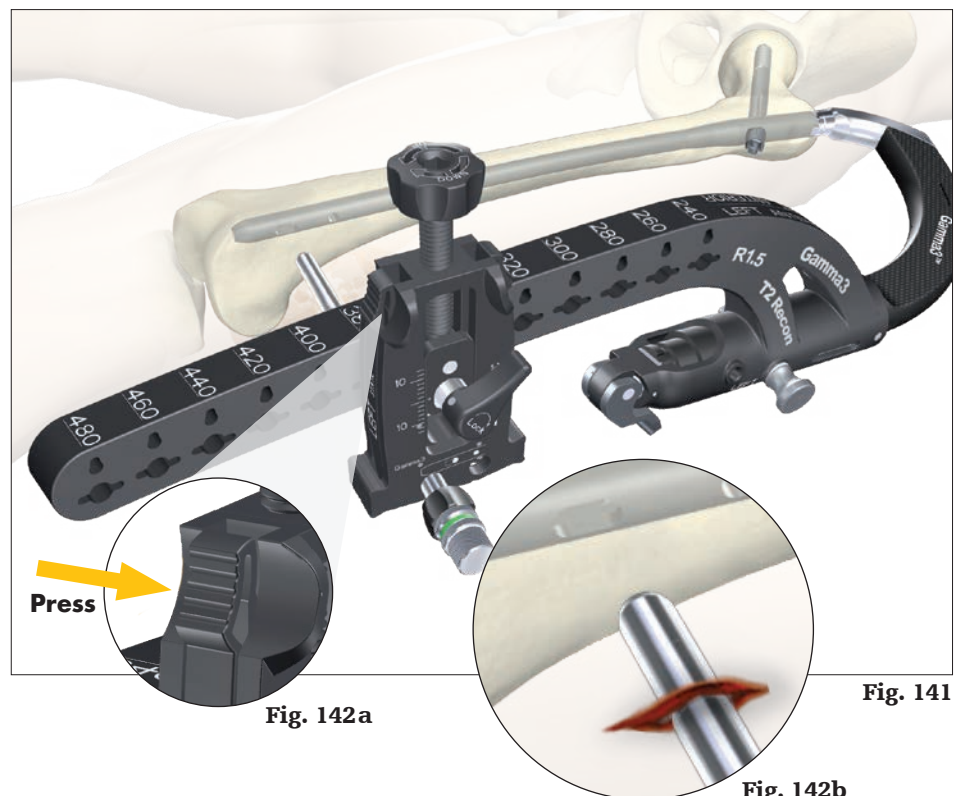

Fig. 142a

Fig. 141

Fig. 142b

Operative technique

If alignment of nail tip and sleeve is still collinear, remove the trocar and thread the green coded 4.2mm drill into the drill sleeve. Now you may start the drilling procedure.

⚠ CAUTION

These following points must be considered in order to perform a proper distal locking procedure:

- Ensure that the nail holding bolt is fully tightened.
- Ensure that the fixation bolt is still in place and lever is fully tightened.
- Avoid soft tissue pressure on the distal locking sleeve assembly. Therefore, the skin incision would be made (co-linear) in the direction of the sleeve assembly.
- With the trocar removed, check that the distal locking sleeve assembly is in contact with the lateral cortex of the femur and is locked securely with the speedlock sleeve knob. Confirm final locking screw placement with A-P and lateral fluoroscopic X-ray.
- Neutralize the power tool weight during drilling and do not apply force to the target device.
- Start the power tool before having bone contact with the drill.
- Use sharp and center tipped drills only.



Fig. 143

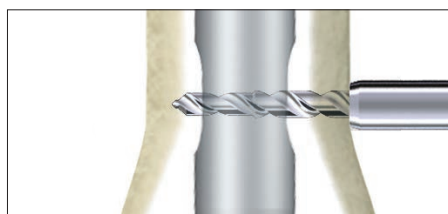

Fig. 144

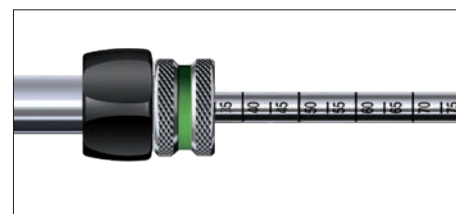

Fig. 145

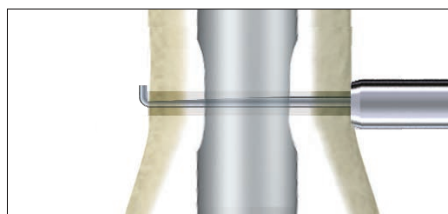

Fig. 146

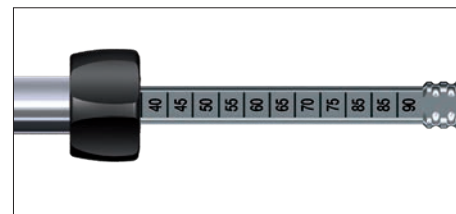

Fig. 147

Drill through the first cortex and as the second cortex is reached (Fig. 144), stop drilling and read the depth measurement on the drill's calibrated scale (Fig. 143 and Fig. 145).

To avoid slippage of the drill on the bone, a finger on the tissue protection sleeve may help for detection and control.

Add the thickness of the cortex, approximately 5mm, to this measurement to select the correct screw length. Now continue by drilling through the second cortex. Remove the drill.

Alternatively, the drilling can be performed by drilling the first cortex, passing the nail hole and then drilling the second cortex, monitored by the image intensifier. The screw length can then be read directly from the scale on the drill.

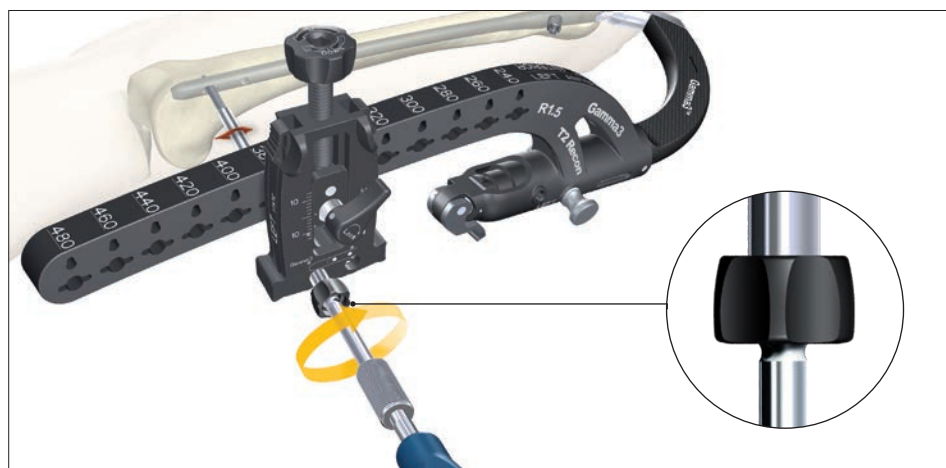

Fig. 148

Operative technique

Screw length measurement is also possible after drilling through the second cortex and using the screw depth gauge. The drill sleeve must be removed and the screw depth gauge may be used through the tissue protection sleeve. Place the small hook on the medial cortex (Fig. 146) and read the required locking screw length from the scale (Fig. 147).

Always verify that the tissue protection sleeve is in good contact to the bone.

After removing the drill and/or screw depth gauge and the drill sleeve, attach the screwdriver bit 3.5mm to the teardrop handle. Insert the 5mm distal locking screw through the tissue protection sleeve by turning the screwdriver clockwise until the mark on the screwdriver shaft approaches the top of the tissue protection sleeve (Fig. 148). Advance the screw head carefully until it is in contact with the cortex.

⚠ CAUTION

Take care not to overtighten. The screw head should just come into contact with the cortex and resistance should be felt.

Leave the screwdriver shaft still connected to the screw head, inside the tissue protection sleeve and only remove the teardrop handle. The tissue protection sleeve should remain in contact with the lateral cortex. This will help stabilize the system when performing the second screw insertion procedure.

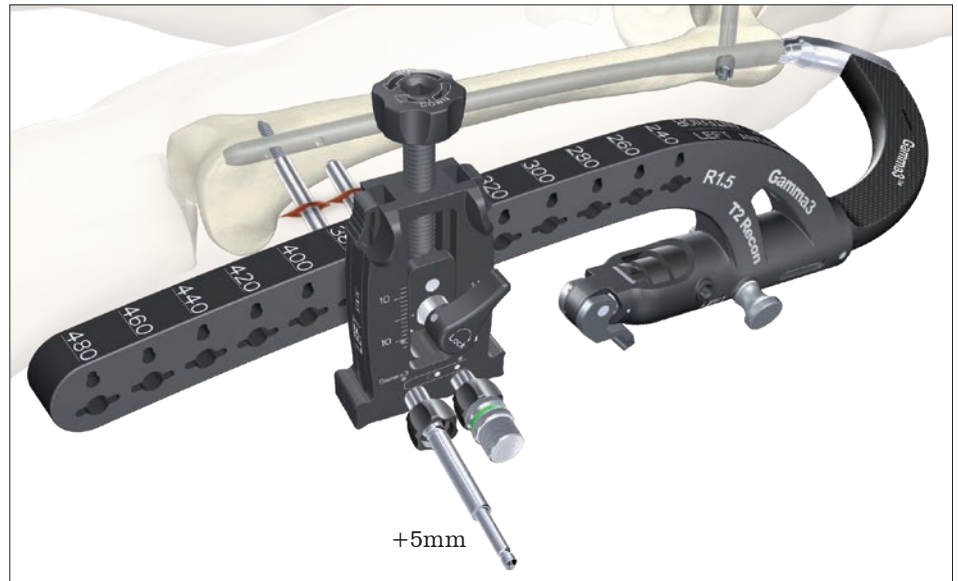

Fig. 149

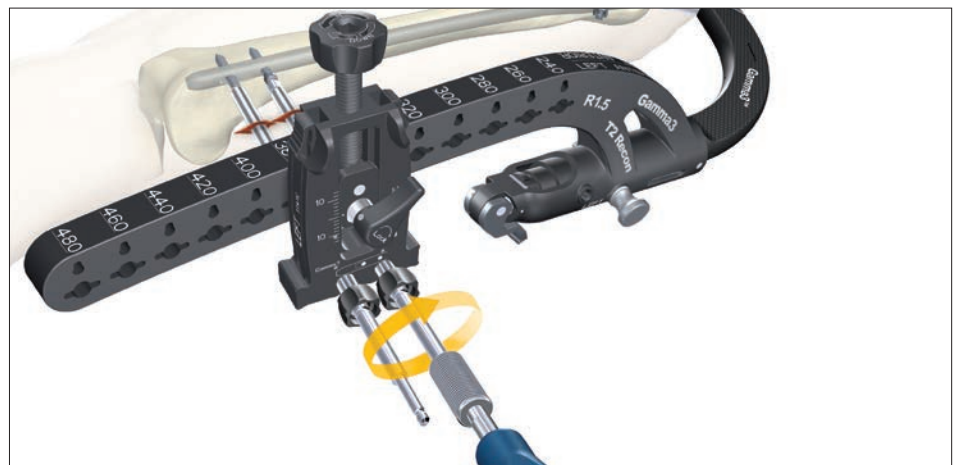

Fig. 150

Operative technique

With the screwdriver shaft or drill still inserted through the sleeve, the drill sleeve and the trocar are assembled with the second tissue protection sleeve and then inserted through the most proximal targeting hole of the adjusting device and advanced to the skin (Fig. 149).

Using the image intensifier, check that the sleeve and the nail are still in-line. If not, readjust the adjusting device as described previously. Proceed with the skin incision, insert the drill sleeve, and use the green coded 4.2mm drill.

Remove the drill sleeve and insert the selected 5mm screw, using the teardrop handle and the screwdriver bit (Fig. 150). Before the distal targeting device is disassembled a final check with the image intensifier should be made to confirm the correct position and the appropriate length of both locking screws.

Disassembly

Press the sleeve fixation button and remove the screwdrivers and sleeves (Fig. 151). Open the fixation lever of the distal targeting device.

Now withdraw the fixation bolt and put the fixation bolt back in the fixation bolt storage pocket of the distal targeting device (Fig. 152).

Remove the distal targeting device from the target device (Fig. 153). Complete the surgery with the end cap insertion (refer to section 'End cap insertion').

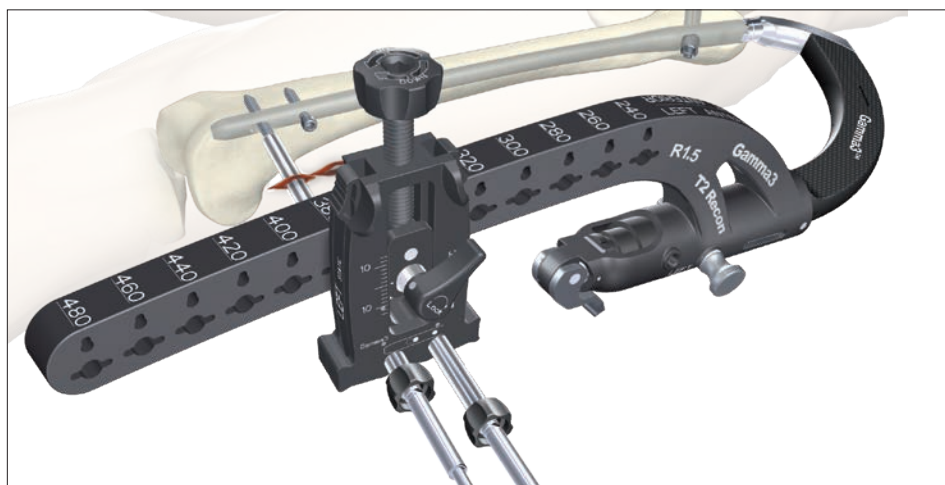

Fig. 151

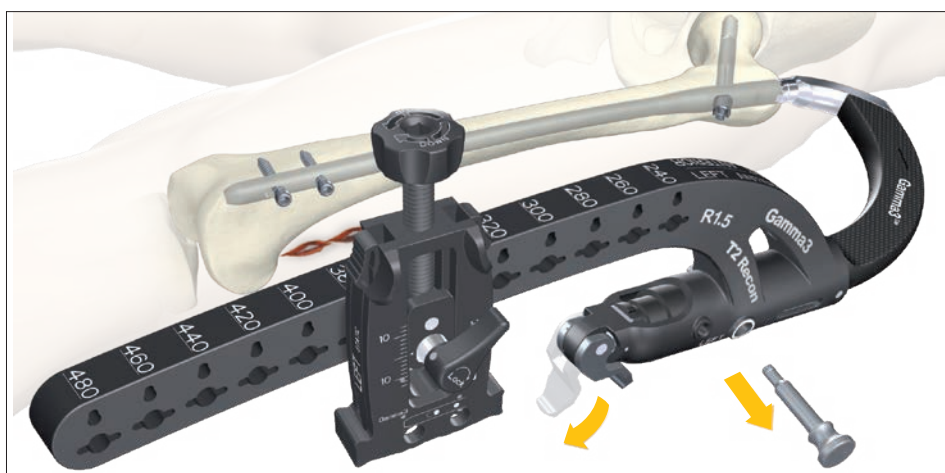

Fig. 152



Fig. 153

Operative technique

Distal screw locking

Trochanteric nails

Gamma3 nails offer the possibility to be locked distally either dynamically or statically. Refer to Fig. 154.

The speedlock sleeve is set to the static or dynamic position.

Assemble tissue protection sleeve, drill sleeve and trocar and advance the assembly through the hole of the target device down to the skin (Fig. 155).

A small incision is started at the tip of the trocar, and is extended down to the lateral cortex.

The trocar will extend beyond the sleeve when the tissue protection sleeve has reached the lateral cortex. Turn the speedlock sleeve knob clockwise to lock the sleeve assembly. Refer to Fig. 156.

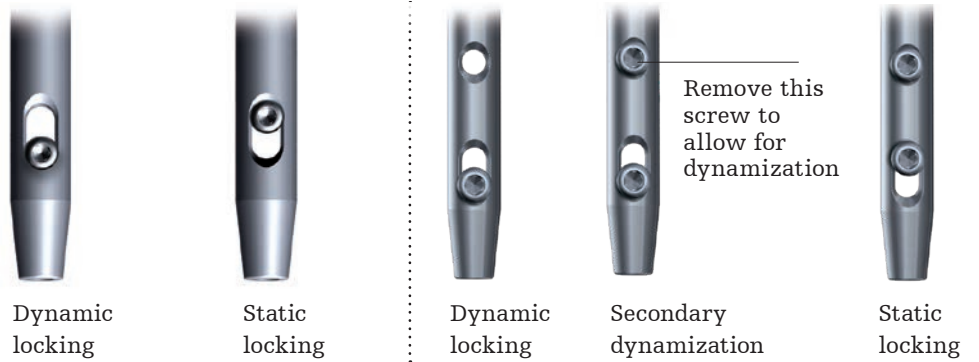

Fig. 154

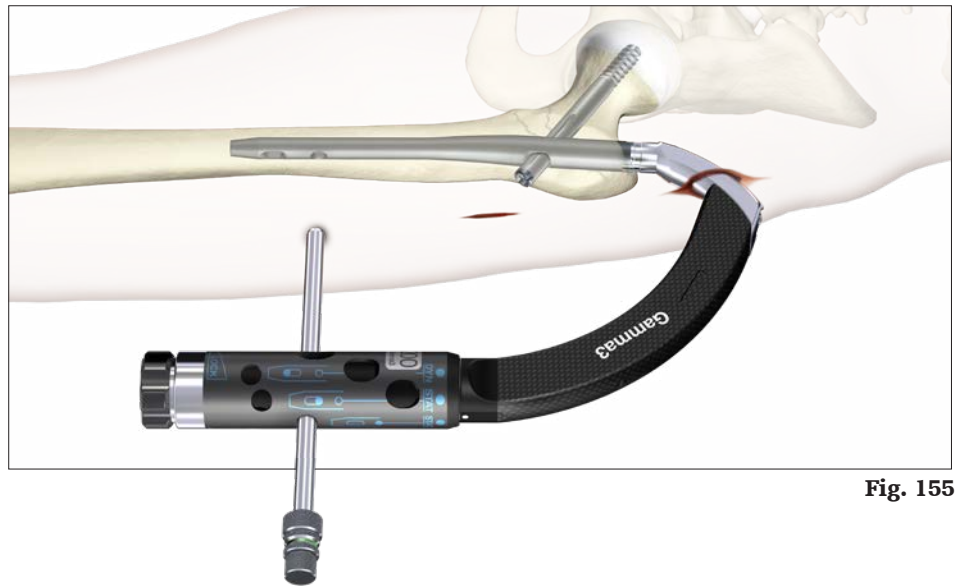

Fig. 155

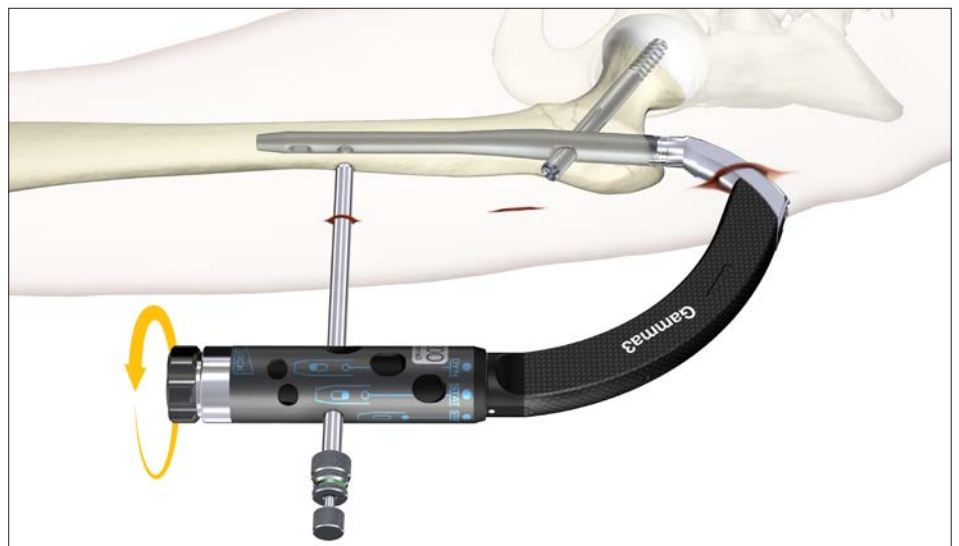

Fig. 156

Operative technique

The trocar is now removed and replaced by the calibrated green coded 4.2mm drill (Fig. 157). Drill through the first cortex and as the second cortex is reached, read off the measurement on the drill scale. Add the thickness of the cortex, which is approximately 5mm, to this measurement to select the correct screw length (Fig. 158). Proceed to drill the second cortex. Alternatively, the drill can be drilled through the second cortex while monitored by X-ray. The screw length can then be read directly from the scale on the drill (Fig. 159). Start the power tool before having bone contact with the drill. Use sharp and center tipped drills only.

It is also possible to measure the correct screw length using the screw gauge after drilling through the second cortex. The drill guide sleeve must be removed and the screw gauge may be advanced through the tissue protection sleeve. Put the small hook behind the medial cortex and read the required locking screw length from the scale. Refer to the section above titled 'Drilling and locking' for more information.

⚠ CAUTION

Make sure that the tissue protection sleeve/drill sleeve assembly is seated on bone prior to selecting final screw length.

Insert the 5mm distal locking screw through the tissue protection sleeve by using the 3.5mm screwdriver until the mark on the screwdriver shaft approaches the sleeve; advance the screw head carefully until it is in contact with the cortex. Refer to Fig. 160.

⚠ CAUTION

When the mark on the screwdriver shaft reaches the tissue protection sleeve, this indicates that the screw head is near the cortex (Fig. 160). Take care not to overscrew. The screw head should come just into contact with the cortex and resistance should be felt.

⚠ CAUTION

These following points must be considered in order to perform a proper distal locking procedure:

- Ensure that the nail holding bolt is fully tightened.
- Avoid soft tissue pressure on the distal locking sleeve assembly. Therefore, the skin incision would be made (co-linear) in the direction of the sleeve assembly.
- With the trocar removed, check that the distal locking sleeve assembly is in contact

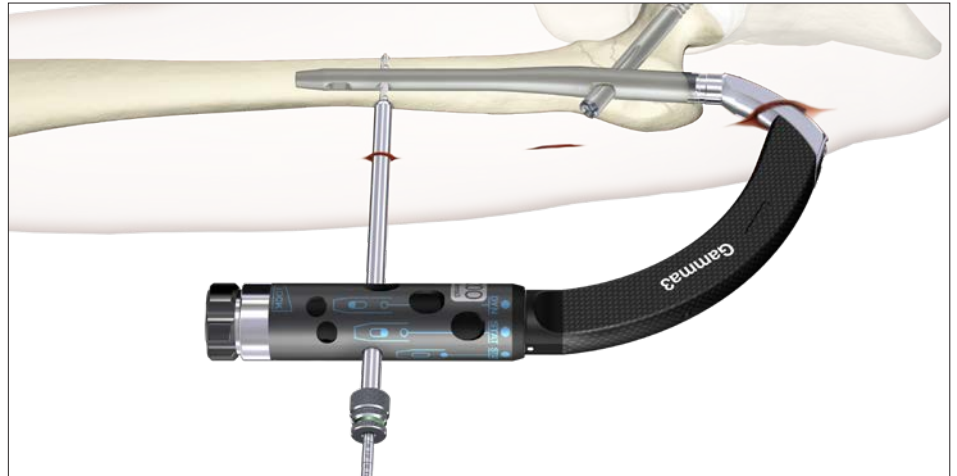
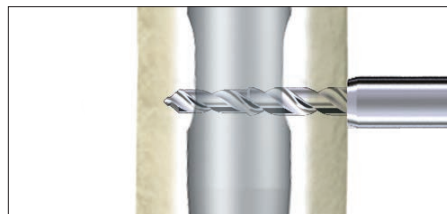

Fig. 157



+5mm



Fig. 158



direct read out



Fig. 159

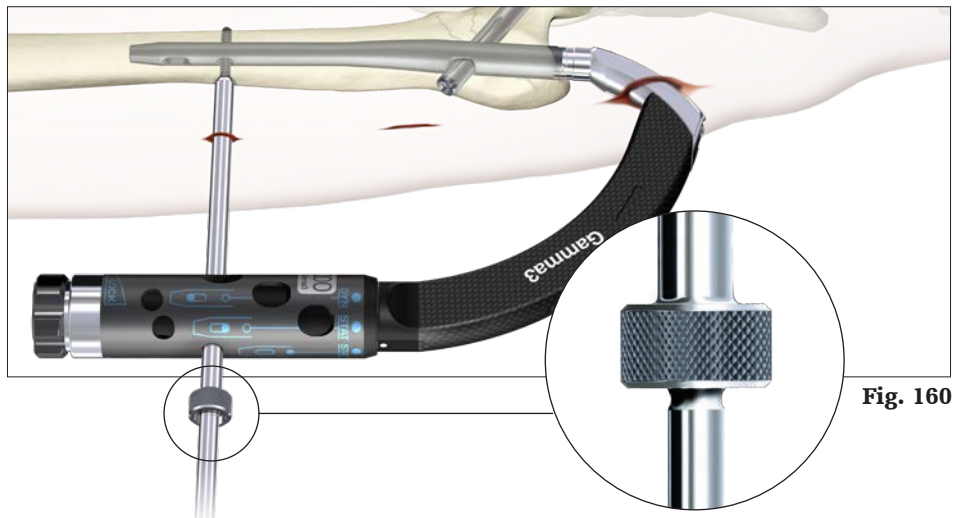

Fig. 160

with the lateral cortex of the femur and is locked securely with the speedlock sleeve knob. Confirm final locking screw placement with A-P and lateral fluoroscopic X-ray.

- Neutralize the power tool weight during drilling and do not apply force to the target device.
- Start the power tool before having bone contact with the drill.
- Use sharp and center tipped drills only.

Operative technique

Long nails

Gamma3 Long Nails can be locked distally either by freehand technique or the use of the distal targeting system, as described in the 'Distal targeting system' section.

Freehand technique

The freehand technique is one option to fix the distal bone fragment to the nail using locking screws. Length and rotational alignment of the leg must be checked before locking the nail. The initial step is to position the image intensifier so that the distal hole of the nail appears perfectly round. Naturally, these visualization steps refer to the appearance of the round and not the oblong holes. If the holes appear to be ellipses in either the vertical or horizontal plane, the image intensifier position must be adjusted appropriately (Fig. 161, Fig. 162). It is advised to correct the image one plane at a time.

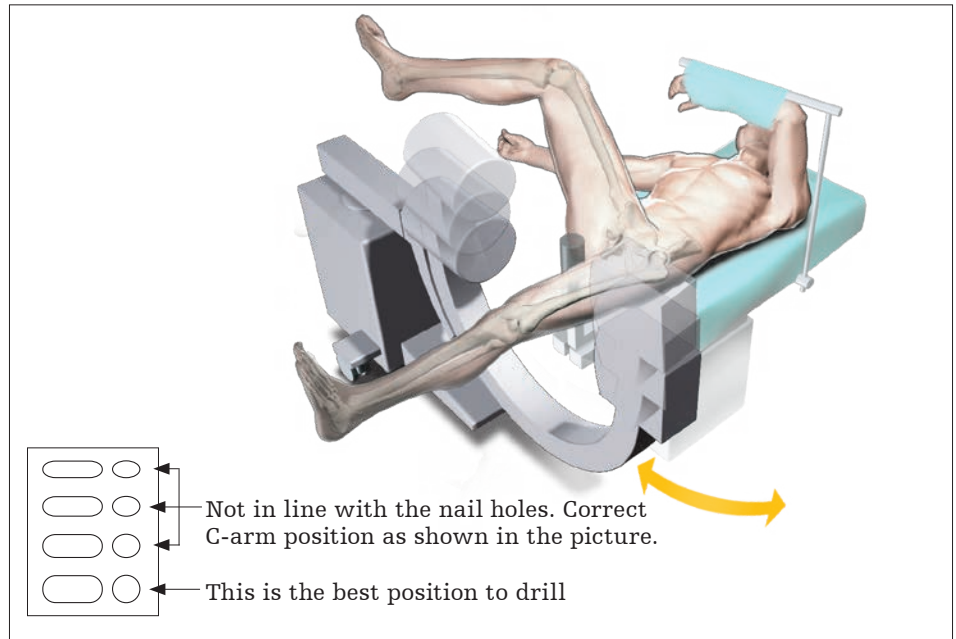

Fig. 161

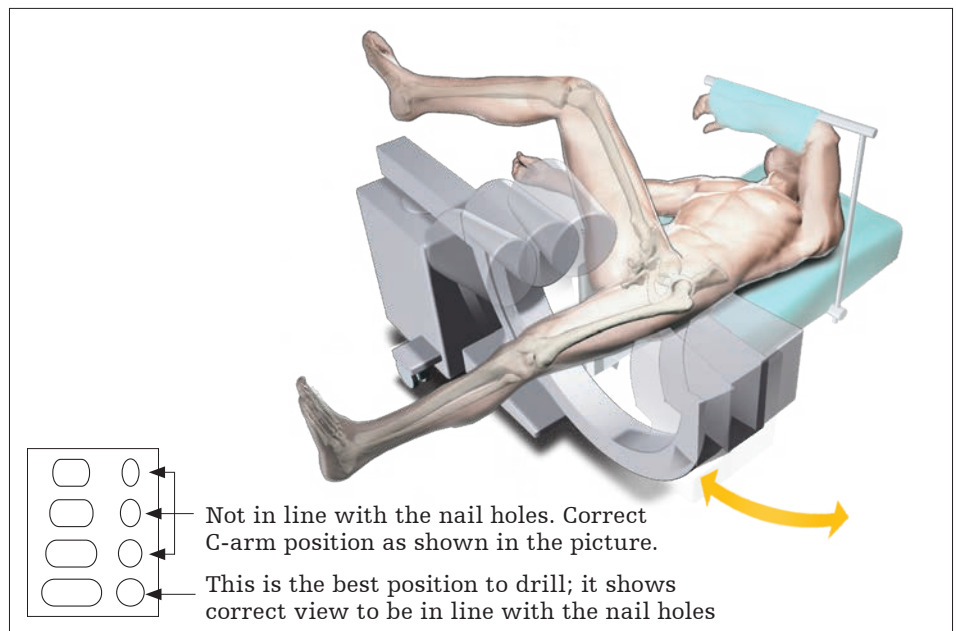

Fig. 162

Operative technique

Once the image intensifier is correctly positioned, indicate the appropriate position on the skin and perform the incision down to the bone. Use the center tipped $\text{\O}4.2\text{mm} \times 180\text{mm}$, green coded drill and place the tip of the drill at an oblique angle. On the X-ray, the drill tip should be positioned in the center of the hole (Fig. 163). Tilt the drill into the hole axis and carefully drill through the first cortex and the nail until resistance of the second cortex is felt (Fig. 164). Measure the screw length on the screw scale by adding the thickness of the second cortex and proceed drilling.

Alternatively, the drill can be drilled through the second cortex while monitoring progress with the image intensifier. The screw length can then be read directly from the screw scale on the drill (Fig. 165, Fig. 166).

It is also possible to measure the correct screw length using the free hand screw gauge. After drilling through the second cortex, remove the drill and advance the small hook of the screw gauge through the holes behind the medial cortex and read the required locking screw length (Fig. 167).

Insert the 5mm distal locking screw through the skin by using the 3.5mm screwdriver. Advance the screw head carefully until it is in contact with the cortex.

⚠ CAUTION

Take care not to overtighten. The screw head should just come into contact with the cortex and resistance should be felt.

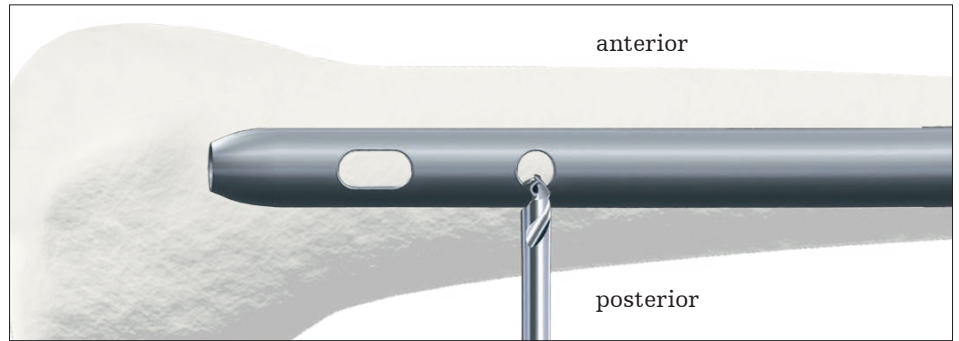

Fig. 163

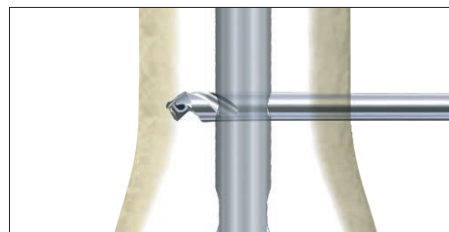

Fig. 164
Add thickness of the cortex to the read out value

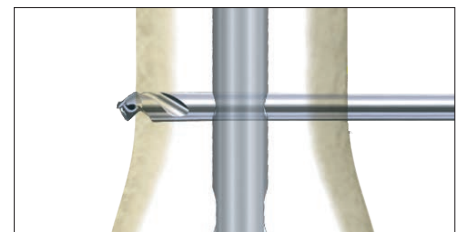

Fig. 165
Direct read out

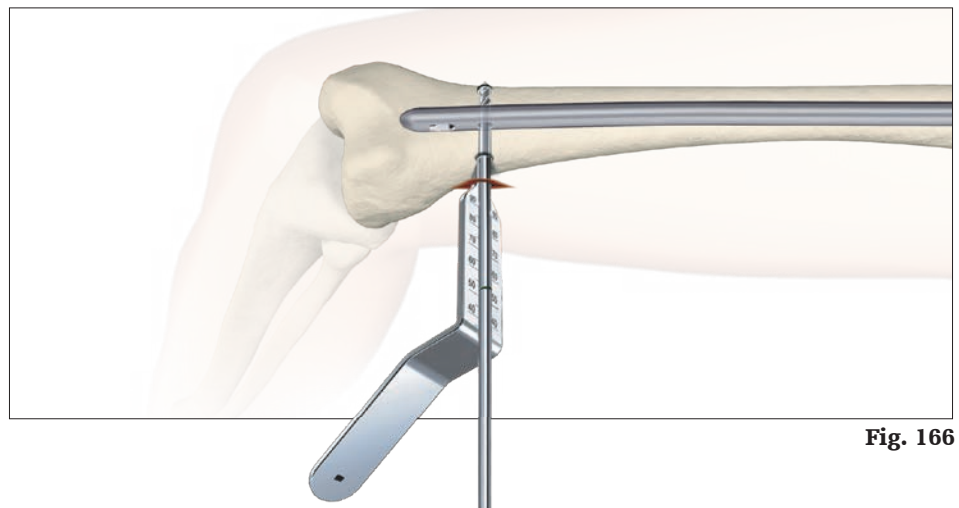

Fig. 166

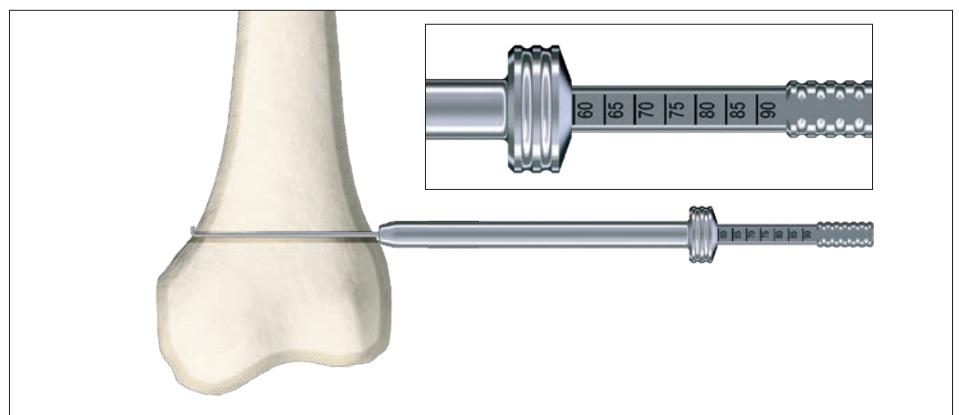

Fig. 167

Operative technique

End cap insertion

An end cap may be used to prevent bony ingrowth.

⚠ CAUTION

It is recommended to use an end cap to close the proximal part of the nail to prevent bony ingrowth.

Leave the screwdriver for the distal locking in place and remove the nail holding screw using the ball tip screwdriver, spreading screwdriver or screwdriver strike plate. Load the end cap (size 0) to one of the screwdrivers and pass the assembly through the top of the target device down into the nail (Fig. 168).

Turn the handle clockwise until it stops mechanically. Remove the screwdriver, the distal screwdriver and the distal sleeves and remove the target device (Fig. 169).

Alternatively, the end cap could also be inserted free hand after removal of the target device. Extension end caps (size 5 or 10) do not pass through the target device post and therefore need to be inserted free hand.

NOTICE

Extended end caps may only be inserted free-hand after the target device has been removed.



Fig. 168

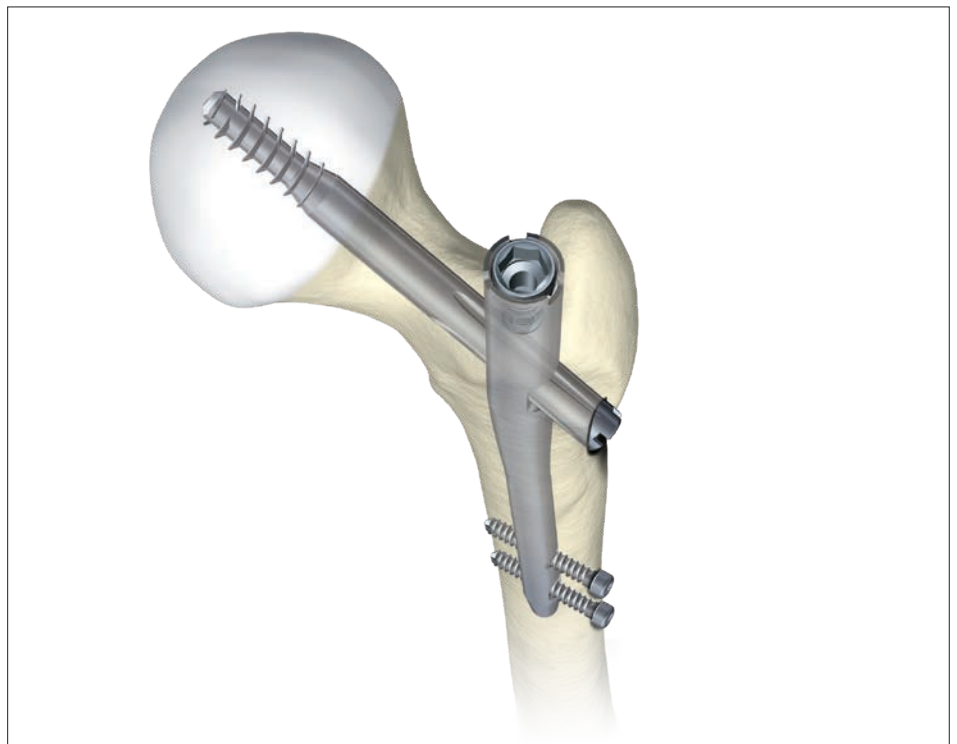

Fig. 169

Operative technique

Post-operative care and rehabilitation

Active and passive mobilization of the lower limbs may be started immediately. The injured limb should be kept elevated.

For stable fractures with dynamic locking, full weight-bearing walking may be started immediately. For unstable fractures with static locking, immediate full weight-bearing walking is allowed in fractures with good bone contact.

For fractures with poor bone contact due to comminution, partial weight-bearing walking is allowed for the first 6 to 8 weeks. Full weight-bearing walking can be commenced when there is a bridging callus formed as evident on the follow up X-ray.

Operative technique

Extraction

Where implant extraction is indicated, please proceed as follows:

Step 1: Distal screw removal (Fig. 170)

Remove the distal screw(s) using the 3.5mm screwdriver after making an incision through the old scar.

Step 2: Lag screw driver attachment (Fig. 171)

Make a small incision through the old scar below the greater trochanter to expose the outer end of the lag screw. Remove any bony ingrowth which may be obstructing the outer end or internal thread of the lag screw as necessary to enable the lag screwdriver to engage fully.

The k-wire is then introduced into the lag screw. The lag screwdriver is engaged with the distal end of the lag screw. The lag screw guide sleeve may help for easier attachment.

⚠ CAUTION

Check that bony ingrowth does not obstruct secure engagement of the lag screwdriver, otherwise the lag screw or screwdriver may be damaged and extraction will be much more difficult. Tighten the thumbwheel clockwise.

Step 3: End cap and set screw removal (Fig. 172)

An incision is made over the proximal end of the nail, the proximal end cap (if used) is removed using the ball tip screwdriver, spreading screwdriver or screwdriver strike plate, and the set screwdriver is engaged with the set screw. The screw is rotated counterclockwise until the lag screw can be removed.

⚠ CAUTION

As the target device is not connected to the nail, we recommend using the straight set screwdriver for better guidance through the soft tissue to get access to the set screw.

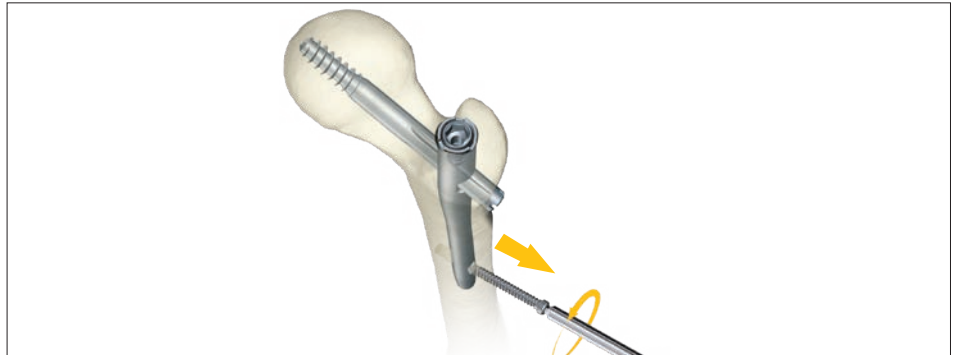

Fig. 170

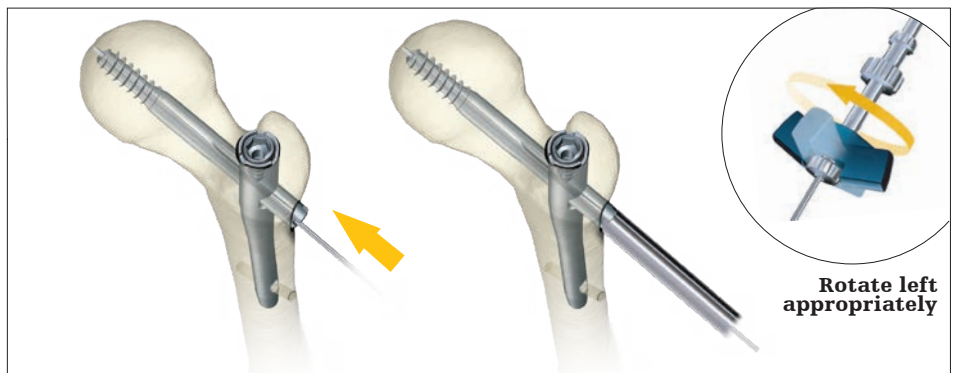

Fig. 171

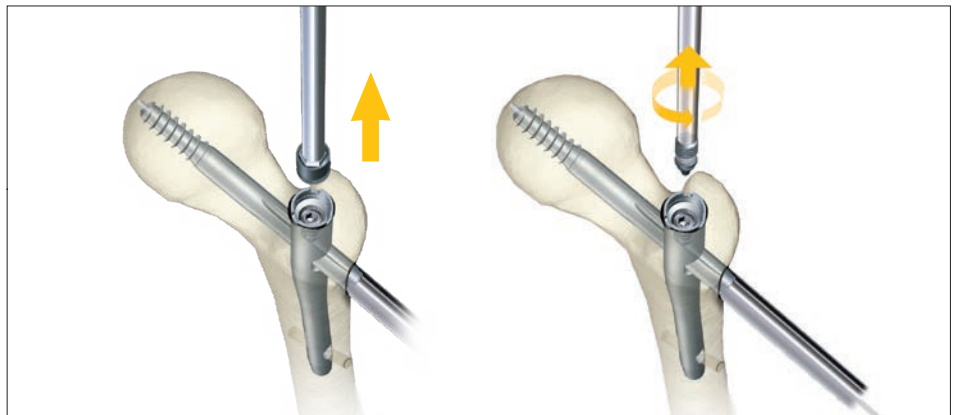

Fig. 172

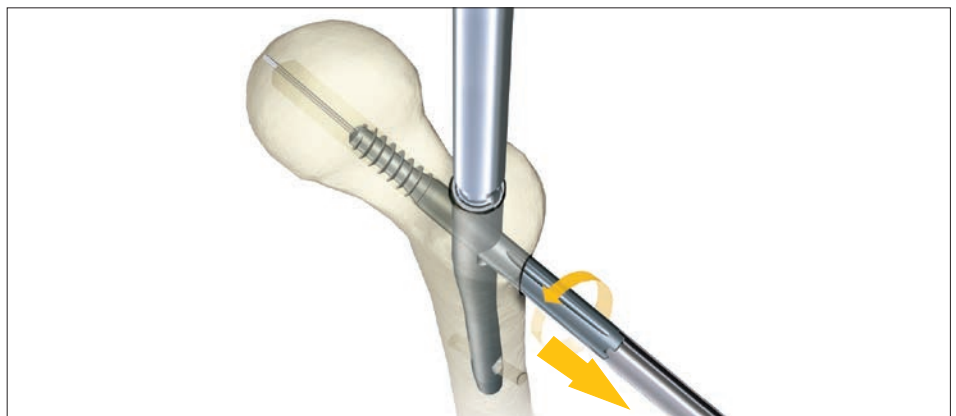

Fig. 173

Operative technique

Step 4: Lag screw extraction (Fig. 173)

The nail extraction adapter is then threaded and tightened into the proximal end of the nail. The lag screw is extracted by counterclockwise rotation and pulling of the lag screwdriver. The k-wire must then be removed.

Step 5: Nail extraction (Fig. 174)

An appropriate sliding hammer assembly (e.g. universal rod in combination with slotted hammer) is attached to the nail extraction adapter and the nail is extracted.

As an alternative for implant extraction the Stryker implant extraction system can be used.

For details, please refer to the “implant extraction set” guide or ask your Stryker representative for further assistance.

U-blade lag screw extraction

Follow steps 1 to 3 above. Remove the end cap of the u-blade lag screw by using the straight set screwdriver.

Step 4a: U-blade extraction

Mount the u-blade connector over the k-wire to the u-blade by turning it clockwise. Check that no ingrowth or soft tissue is between the connecting parts. If the thread of the connector is engaged with the u-blade, retract the u-blade connector (Fig. 175). If the u-blade is not loosened at this stage, a rod can be inserted through the holes of the u-blade connector assembly to provide a strong handle for pulling it back.

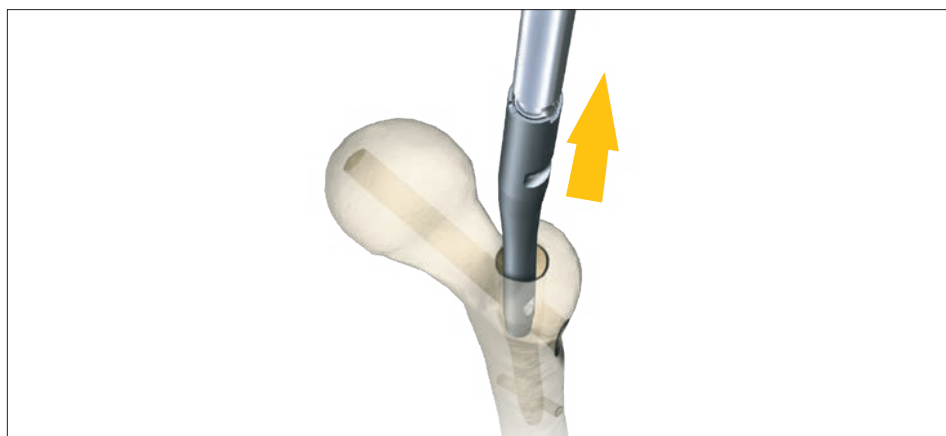

Fig. 174

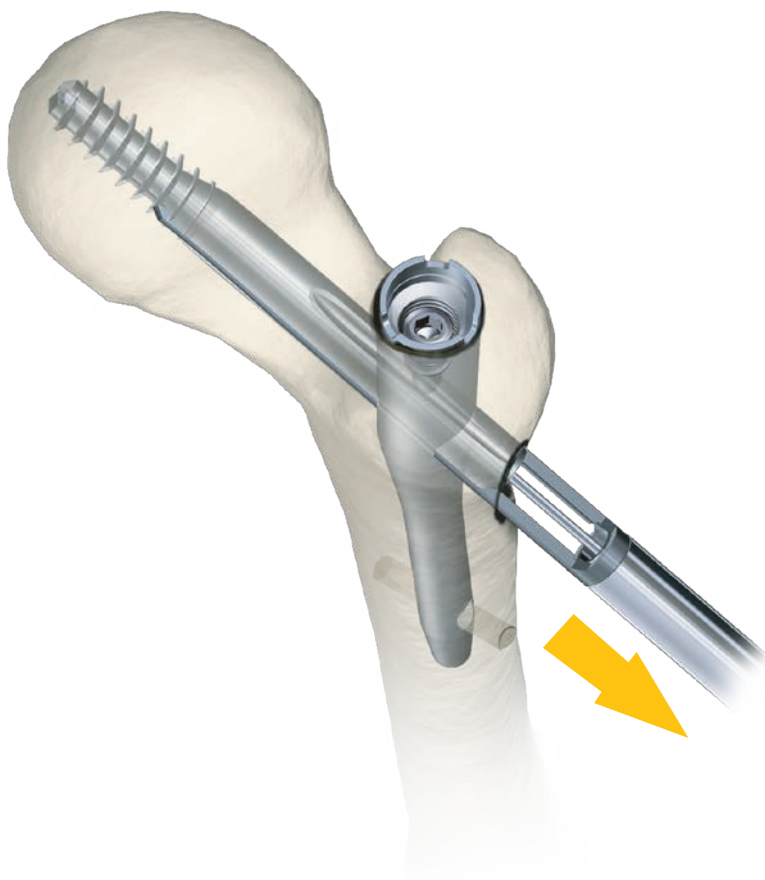

Fig. 175

Operative technique

Alternatively, the u-blade extractor may be used for u-blade extraction (no usage of k-wire).

- Remove the k-wire if already inserted
- Connect the universal rod with the u-blade extractor (Fig. 176)
- Screw in the u-blade extractor into the u-blade (Fig. 177)
- Extract the u-blade using the u-blade extractor (a hammer may be used for extraction) (Fig. 178, Fig. 179)
- Detach universal rod from u-blade extractor with the help of a 10mm spanner
- Detach the u-blade from the u-blade extractor

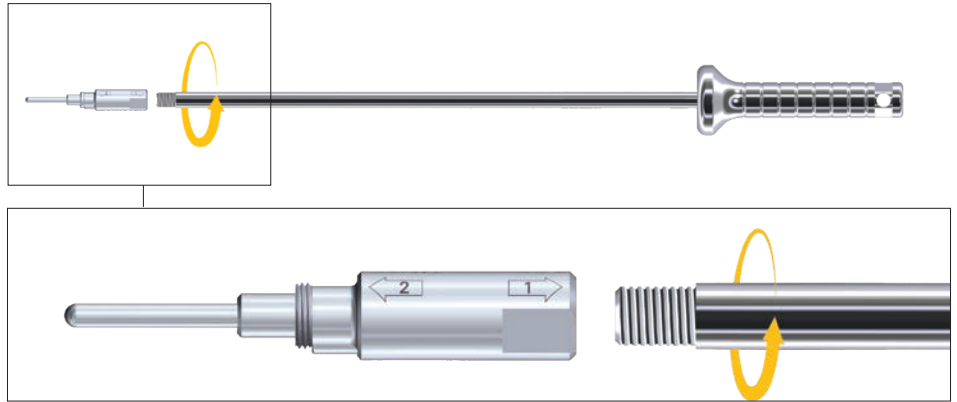

Fig. 176

Step 4b: U-blade lag screw extraction

The u-blade lag screwdriver is passed over the k-wire and engaged with the distal end of the u-blade lag screw. Make sure that the two pegs of the u-blade lag screwdriver fit to the u-blade lag screw. Tighten the thumbwheel clockwise.

⚠ CAUTION

Check that soft tissue does not obstruct secure engagement of the u-blade lag screwdriver, otherwise the u-blade lag screw or screwdriver may be damaged and extraction will be much more difficult.

Follow steps 4 and 5 of lag screw extraction.

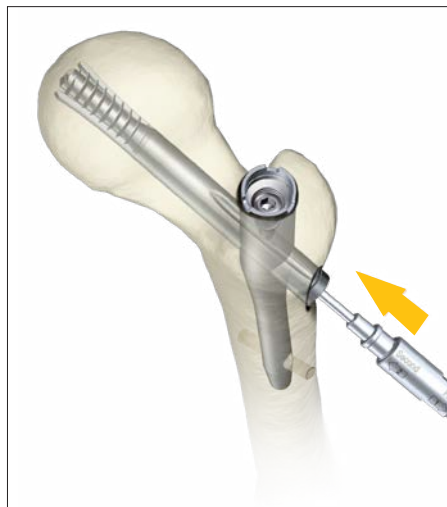

Fig. 177



Fig. 178

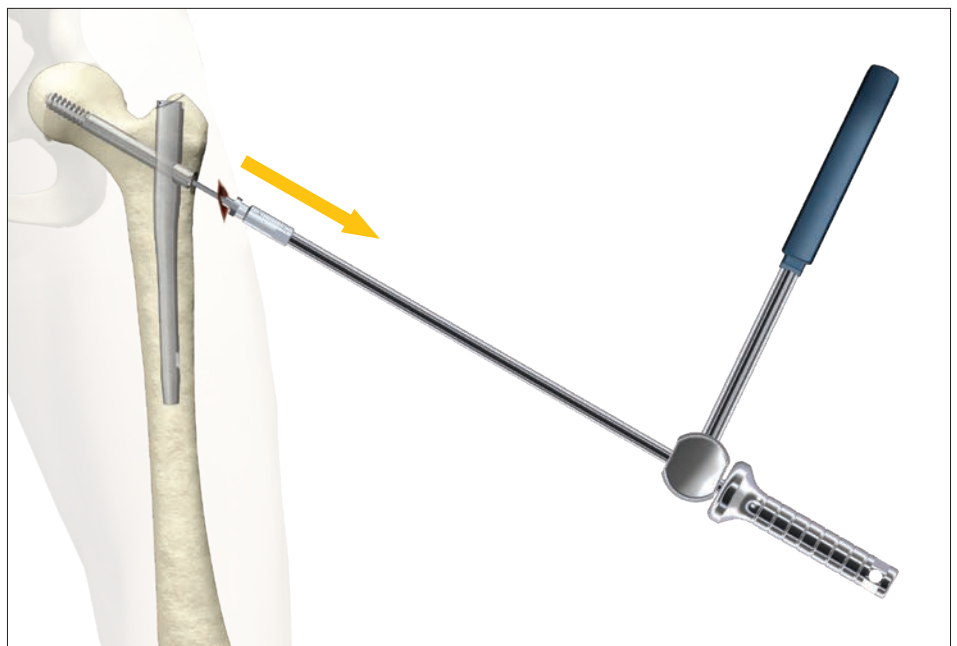

Fig. 179

This document is intended solely for the use of healthcare professionals. A surgeon must always rely on his or her own professional clinical judgment when deciding whether to use a particular product when treating a particular patient. Stryker does not dispense medical advice and recommends that surgeons be trained in the use of any particular product before using it in surgery.

The information presented is intended to demonstrate a Stryker product. A surgeon must always refer to the package insert, product label and/or instructions for use, including the instructions for Cleaning and Sterilization (if applicable), before using any Stryker product. Products may not be available in all markets because product availability is subject to the regulatory and/or medical practices in individual markets. Please contact your Stryker representative if you have questions about the availability of Stryker products in your area.

The Instructions for Use, Operative Techniques, Cleaning instructions, patient information leaflets and other associated labeling may be requested online at www.ifu.stryker.com or www.stryker.com.

If saving the Instructions for Use, Operative Techniques, Cleaning instructions from the above mentioned websites, please make sure you always have the most up to date version prior to use.

Stryker Corporation or its divisions or other corporate affiliated entities own, use or have applied for the following trademarks or service marks: Bixcut, Gamma3, Stryker. All other trademarks are trademarks of their respective owners or holders.

Content ID: G3-ST-11, 12-2019

Copyright © 2020 Stryker



Manufacturer:

Stryker Trauma GmbH
Prof.-Küntschers-Str. 1-5
24232 Schönkirchen
Germany

stryker.com