

Restoration Modular Revision Hip System

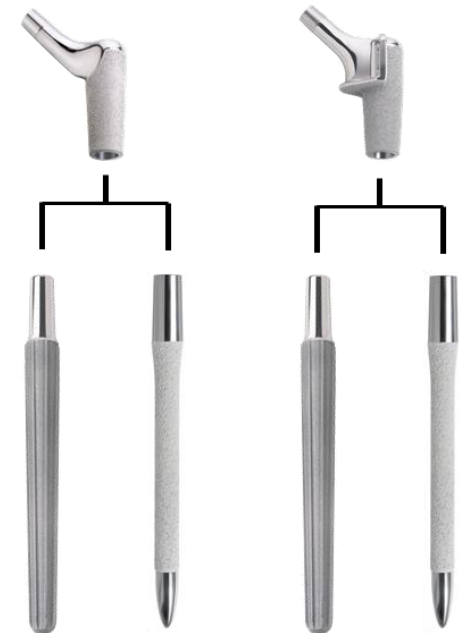

Products may not be available in all markets because product availability is subject to the regulatory and/or medical practices in individual markets. Please contact your sales representative if you have questions about the availability of products in your area.

Stryker's revision hip

Heritage

stryker

1995



2003



2006



2011



2012



2014



2018



Stryker's revision hip

Heritage

stryker

2022

What's next?



Restoration Modular **key messages**

stryker

Established

Versatile

Simple



Established

Shot peening

To enhance fatigue strength and resistance to fretting of the taper junction, Stryker Orthopaedics utilizes a proprietary shot peening process on its Restoration Modular Hip System junction.^{1,2}

Based on bench-top testing, Stryker's proprietary shot peening process has provided a 33% increase in taper fatigue strength compared to non-shot peened junction.^{2*}

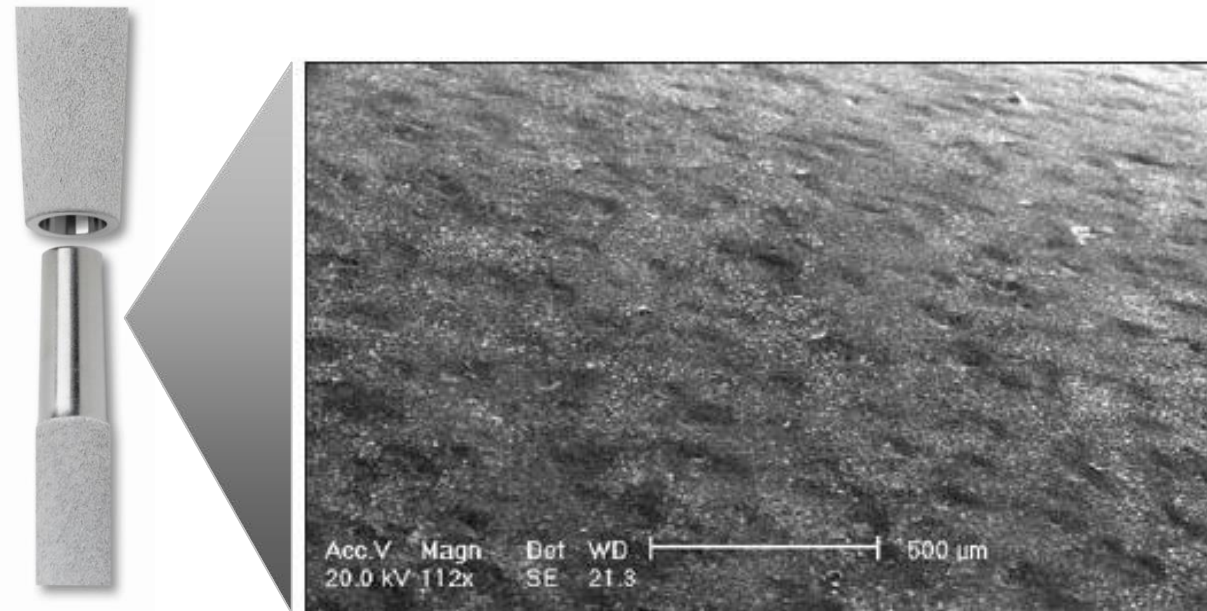

Established

Tried and trusted taper strength

Revision Total Hip Arthroplasty (THA) should not take away from the patient's daily activity.

Based on bench top testing, Restoration Modular has demonstrated that it can withstand daily activity after revision THA such as stair climbing and rising from a seated position. ^{1,2,3,4,5}



Taper junction fatigue testing^{1,2}



Torsion testing⁵

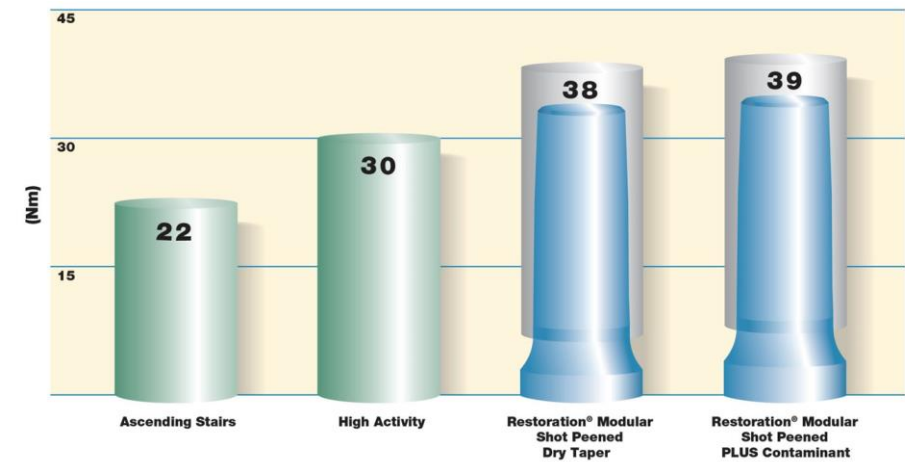

Torsion testing results^{3,4,5}

Established

Shot peening

No reported taper junction failure in over **181,000+** cases since 2003.^{6,7}

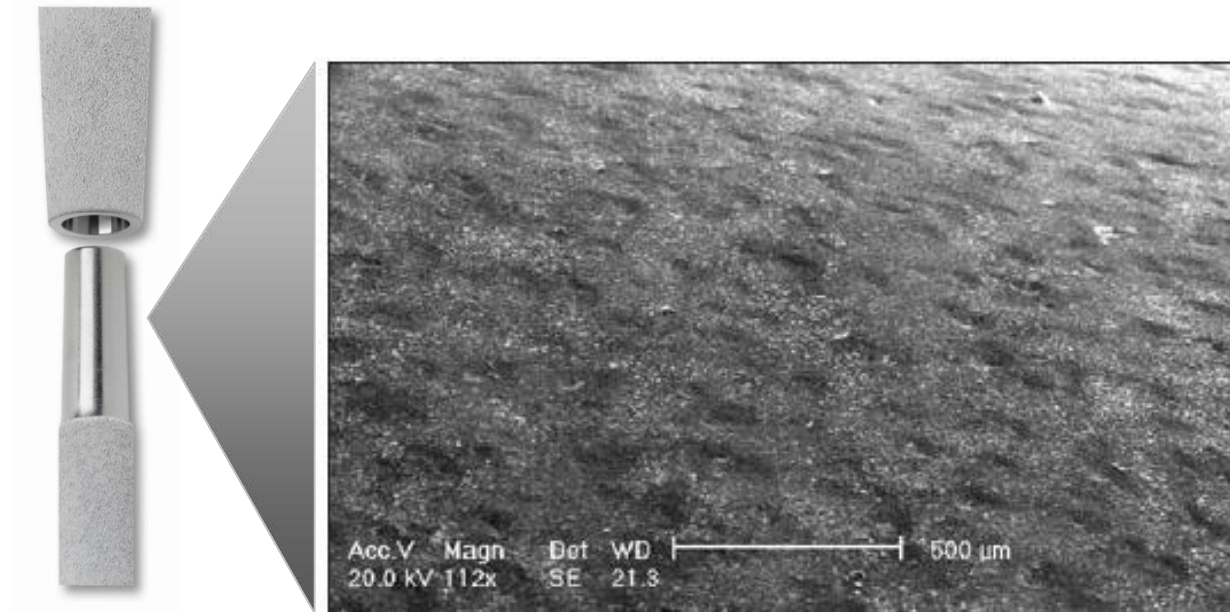

Established

18 years of clinical history

Launched in 2003, there have been over **181,000** Restoration Modular constructs implanted globally.⁶

Below are some key studies for the Restoration Modular Revision Hip System.

Aseptic loosening:

100% aseptic survivorship at a mean follow up of 8.6 (range 5-15) years in 72 hips.⁸

Type 1 & 2 (minor/significant bone loss) vs Type 3 & 4 (massive bone loss):

96.9% survivorship for the **whole group** at 5 years (64 patients with Type 1 & 2 and 52 patients with Type 3 & 4) with no clinically significant difference in subsidence, loosening, dislocation, infection, and medical complications between the groups in a prospective multicenter study.⁹

Patient satisfaction:

99% aseptic survivorship at 6.1 years follow up with **93%** patient satisfaction in 106 patients.¹⁰

Restoration Modular **key messages**

stryker

Versatile



Versatile

Comprehensive portfolio

The Restoration Modular Stem System is designed to allow surgeons to independently achieve the main goals of hip surgery – attain solid fixation and restore hip biomechanics.¹¹

The Restoration Modular System provides the flexibility to help address a range of revision scenarios. Restoration Modular has been providing solutions for femoral **Type 1** through **Type 4** revisions since 2003.^{12,13}

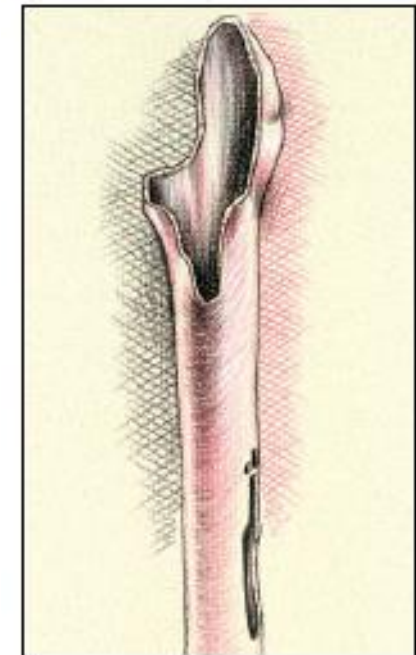
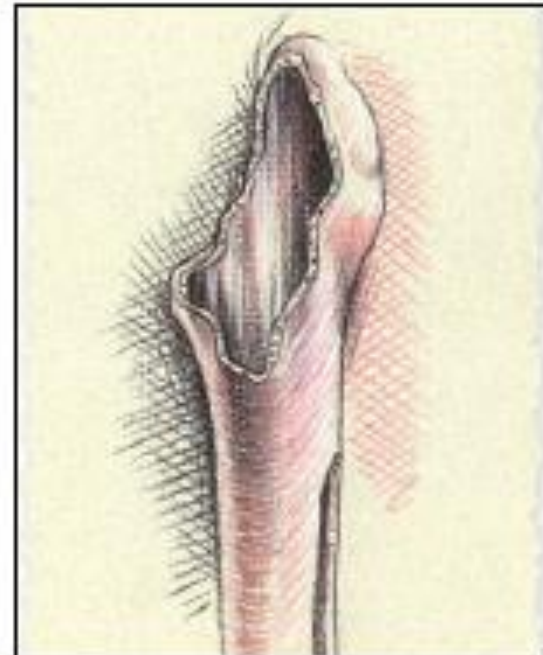
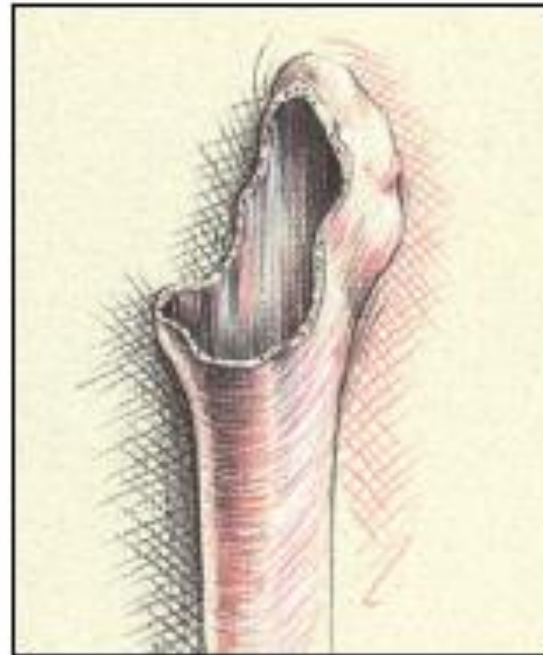
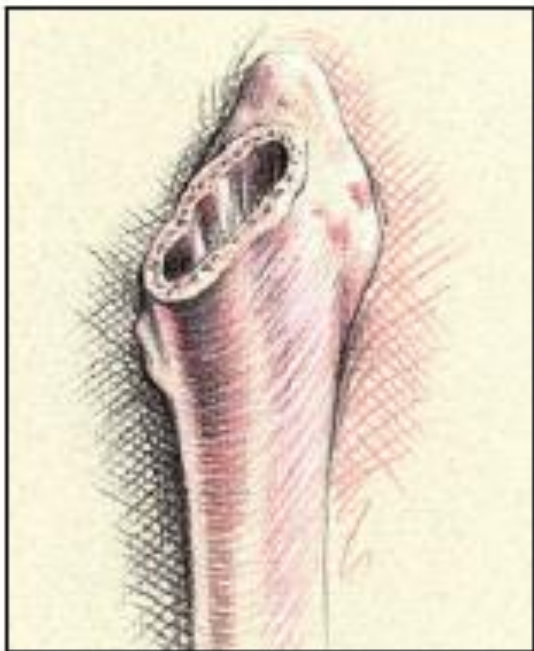

Versatile

Comprehensive portfolio

Cone body

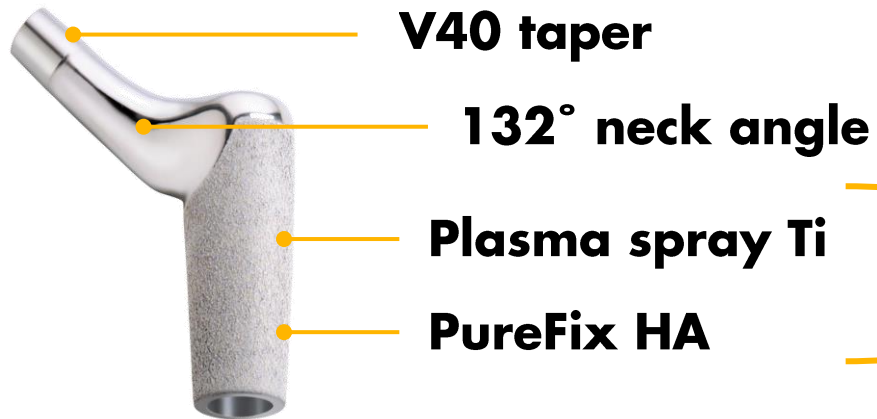

Stryker's plasma spray CP Ti and PureFix Ha coating

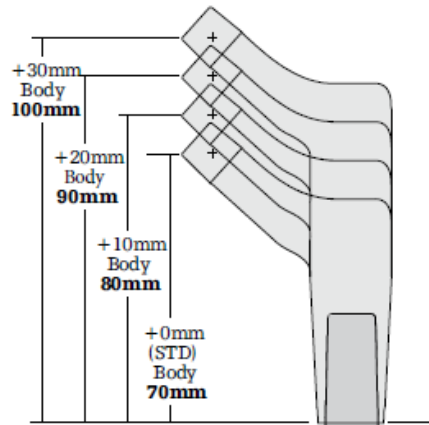

Cone body is designed to help maintain axial and rotational stability.

Body diameter: 19mm, 21mm, 23mm, 25mm, 27mm, 29mm, 31mm

Offset: 34mm, 36mm, 40mm, 44mm (25mm diameter and above)

Body heights are available in 70mm, 80mm, 90mm and 100mm in **all diameters**.

Versatile

Comprehensive portfolio

stryker

Calcar body

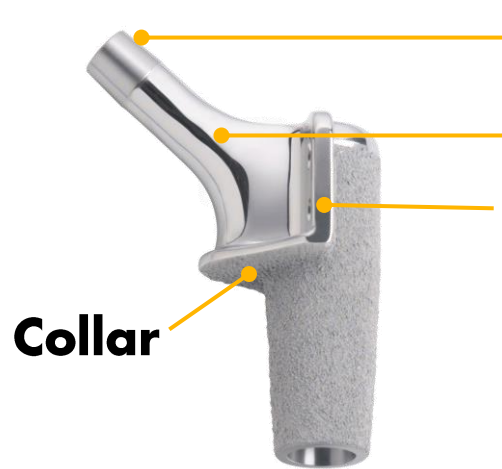

V40 taper

132° neck angle

Vertical flange

- Cobalt Chromium bushings allows 2.0mm Dall-Miles cabling
- Angled holes to allow for cabling to pass around the greater trochanter.

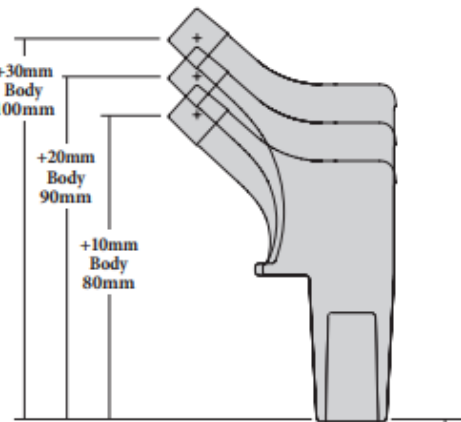

Designed to help maintain axial and rotational stability while enabling **trochanteric reattachment** and **cerclage fixation**.

Body diameter: 19mm, 21mm, 23mm, 25mm, 27mm, 29mm, 31mm

Offset: 34mm, 36mm, 40mm, 44mm (25mm diameter and above)

Body heights are available in 80mm, 90mm and 100mm in all diameters.

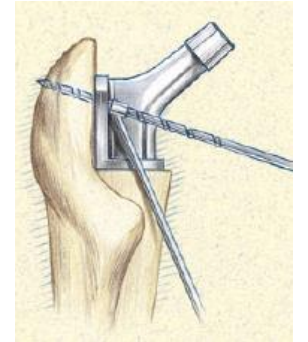

Versatile

Comprehensive portfolio

Plasma stem – cylindrical design to provide distal fixation and rotational stability



● **Shot peening process**

- 33% increase in fatigue strength at taper junction compared to non-shot peened junction.²

● **Plasma spray Ti**

● **PureFix HA**

} Stryker's plasma spray CP Ti and PureFix Ha coating

● **Constant diameter** until the bullet tip

- Designed to achieve initial distal fixation and biological fixation across the stem length in the long term.

Stem length: 127mm, 167mm, 217mm, 267mm, 317mm

Stem diameter: 11 – 26mm in 1mm increments

Versatile

Comprehensive portfolio

Conical stem - designed to provide **immediate** distal fixation and rotational stability



Shot peening process

- **33% increase** in fatigue strength at modular taper junction compared to non-shot peened taper junction.²

3° core taper

2° spline taper

The splines are designed to grow distally for increased distal cortical contact.

Heavy grit-blast

Support the immediate distal fixation in combination with the splines.

Stem length: **115mm**, 155mm, 195mm, 235mm

Stem diameter:

115mm stems: 12 – 23mm in **1mm** increments

155, 195, 235mm stems: 14 – 28mm in **1mm** increments



Versatile

SOMA-verified¹⁴ 115mm conical stem

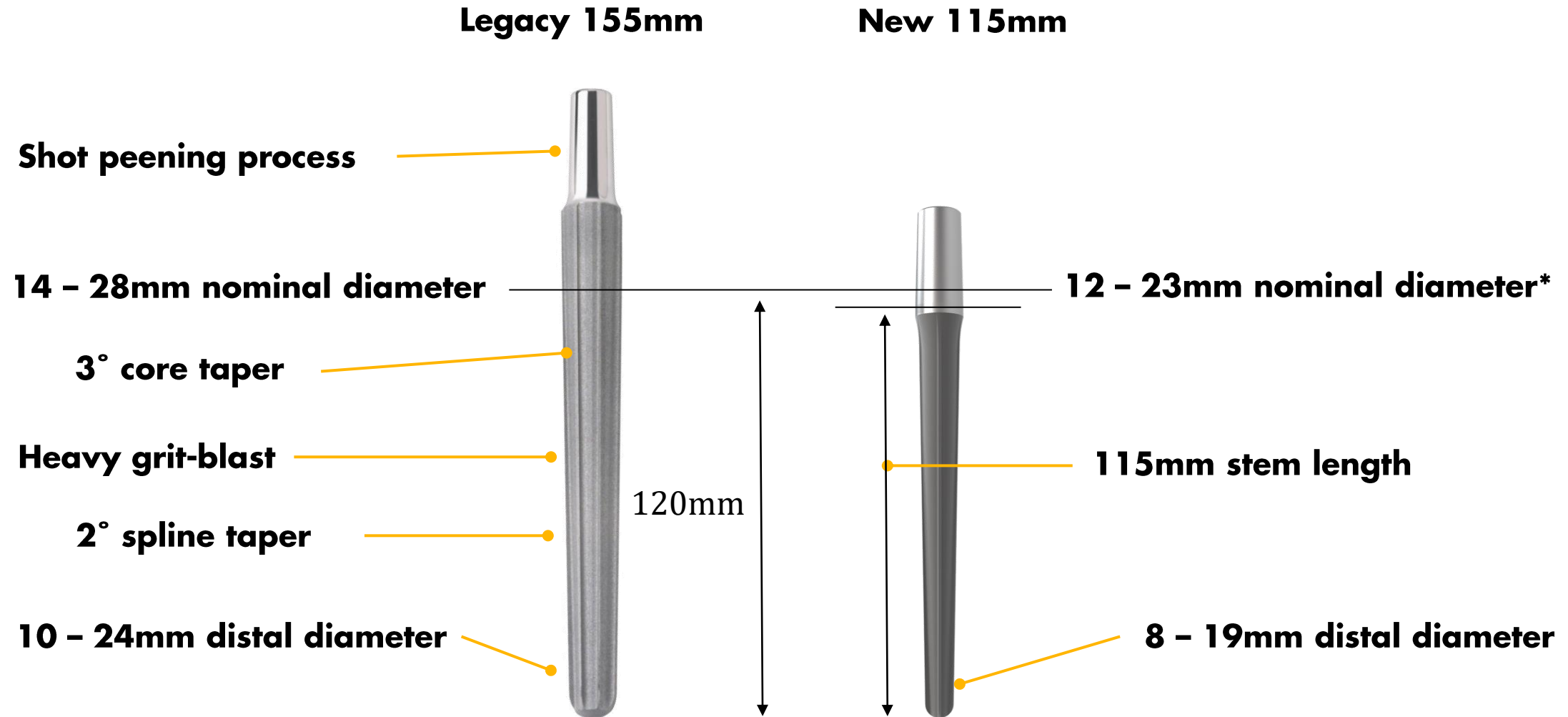

* The 115mm stem diameter is measured at an extrapolated point 120mm from the distal tip. The diameter shown does not represent the diameter at the taper.

Versatile



SOMA-verified¹⁴ 115mm conical stem

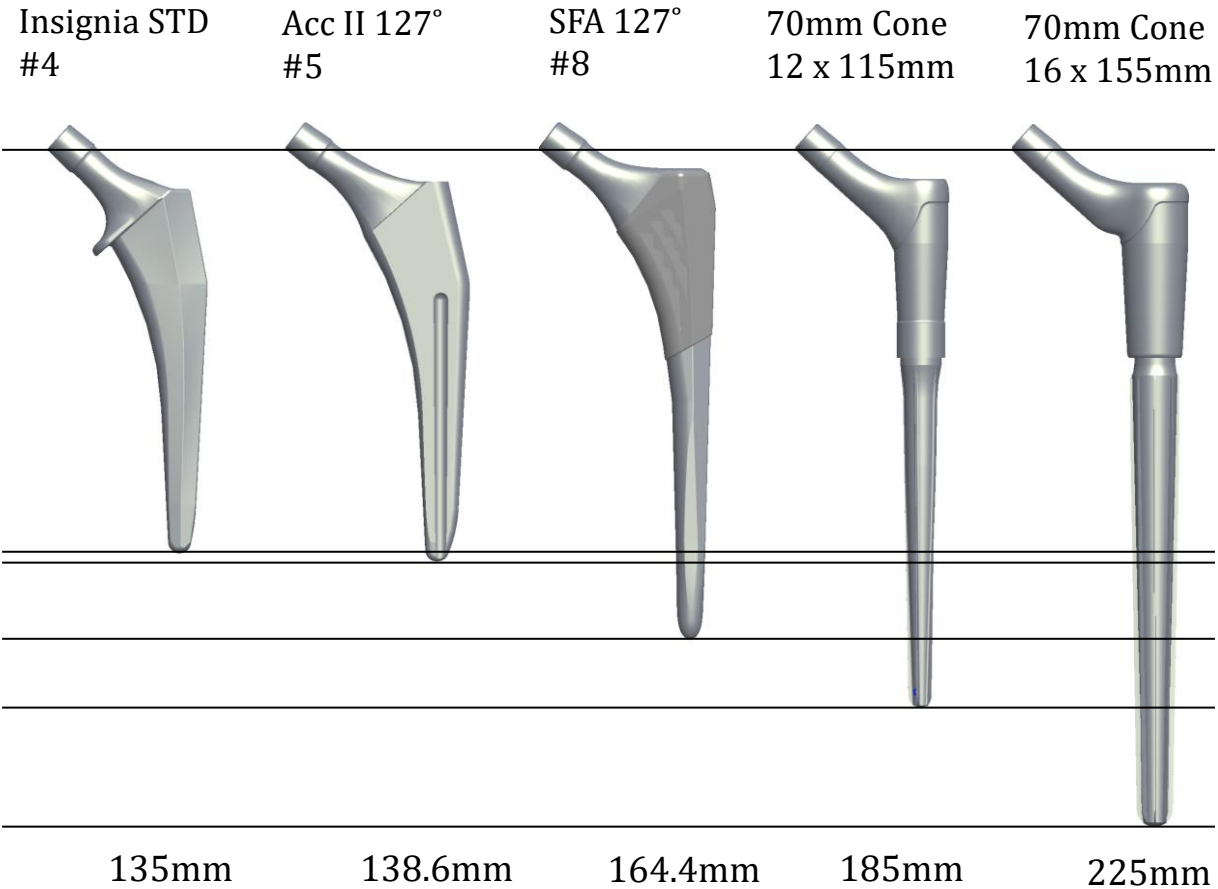

The 115mm conical distal stem is designed to address type 1 to type 4 revision cases, complex primary cases, and cases with Dorr Type A femurs that require shorter stems.^{14,*}

The total construct lengths are measured from the head center to the distal tip.

* Refer to the Instructions for Use for the indications cleared for these products in your country.

Versatile

Ream with confidence

stryker

Stryker's new TiN coated Restoration Modular reamers paired with the 115mm conical stem allow for increased implant options and accommodate varying femoral canals.

The new 115mm conical stem may reduce the risk of femoral shaft perforation in smaller anatomy and patients with a strong femoral A/P bow.

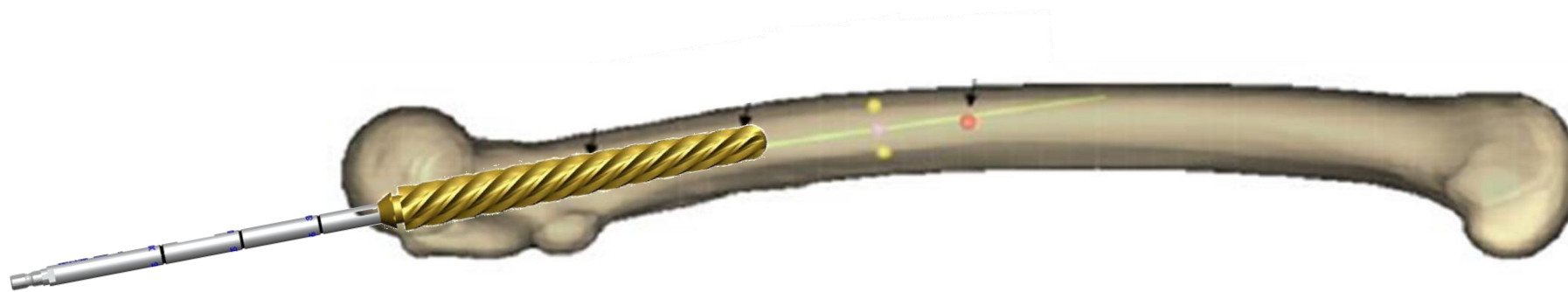

Versatile

Revision portfolio

stryker



Stryker's comprehensive revision portfolio offers a variety of solutions to help meet your needs for revision and complex primary cases and is poised to elevate your care.*

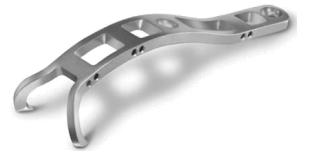

Versatile

Revision portfolio

Trident Tritanium Acetabular System

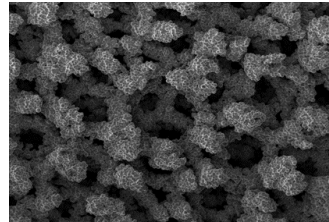

Tritanium surface

- Shell size: 54-80mm
- Smallest liner code: E

Restoration Anatomic Shell



Tritanium surface

- Offset center of rotation
- Anterior/superior beveled rim
- Peripheral rim screws
- Shell size: 54-80mm
- Smallest liner code: C

Trident II Tritanium Multi-hole

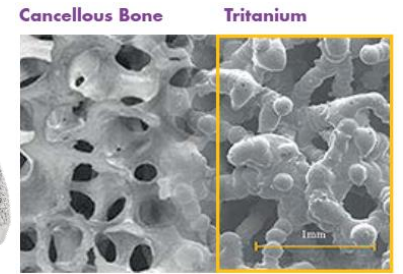

Additive manufactured Tritanium^{15,16,17}

- Surface porosity: 76%
- Average porosity: 60%
- Average pore size: 434 microns
- Coefficient of friction: 1.2
- Shell size: 42-72mm
- Smallest liner code: A
- 54mm liner code: E

Versatile

Revision portfolio



Trident Tritanium Acetabular System

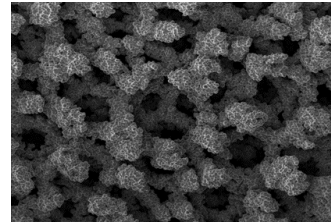

Restoration Anatomic Shell



Trident II Tritanium Multi-hole

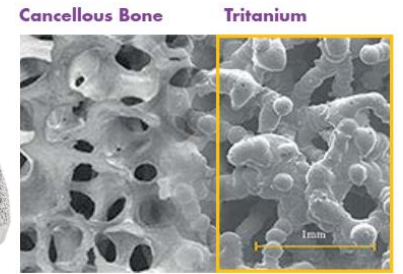

Trident X3 0°

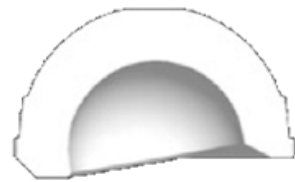

Trident X3 10°

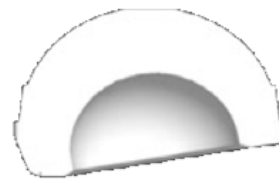

Trident X3
Eccentric 0 & 10°



Trident X3
Constrained



MDM

Versatile

Revision portfolio

stryker

Restoration Acetabular Wedge Augment System



Tritanium surface

- K-wire holes
- Total sizes: 18
- Outer diameter: 46-66mm (4mm increments)
- Inner diameter: 48-68mm (4mm increments)
- Thickness: 15mm, 20mm, 25mm

Dall-Miles cable system



- Trochanteric Grip (small, medium, large)
- Trochanteric Grip plate (medium & large)
- Cables (beaded & non-beaded) 1.6 & 2.0mm
- Available in stainless steel and Vitallium (CoCr)
- Trochanteric grip plate length:
 - Medium – 100mm, 150mm, 200mm
 - Large – 110mm, 160mm, 210mm
- Thickness: 4mm
- Single & double side tensioners

Restoration Modular **key messages**

stryker

Simple



Simple

Streamlined and efficient



Step 1
Distal reaming

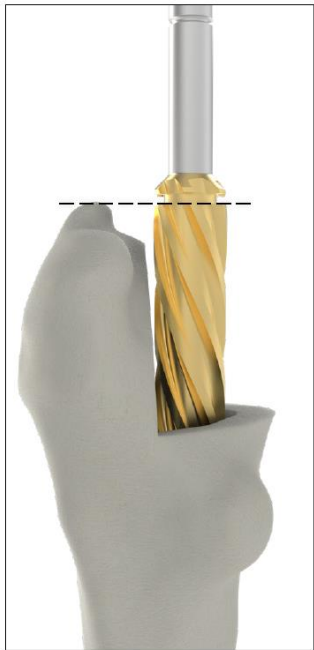

Step 2
Distal stem insertion



Step 3
Proximal body preparation

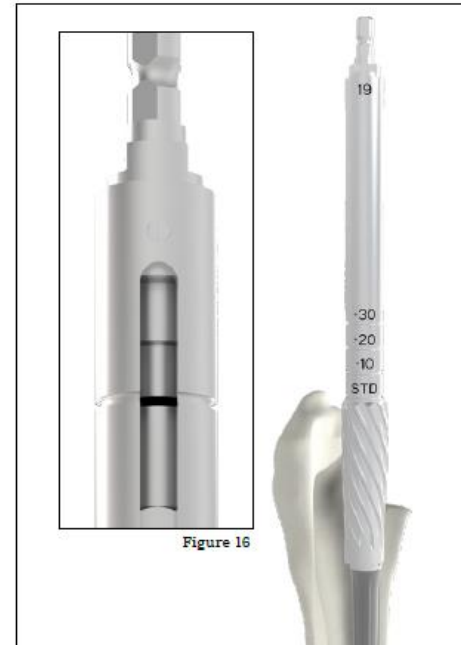

Step 4
Final trial & implant assembly



Restoration Modular instruments were developed for simplicity and ease of use. Simple, straight-forward instruments designed to allow for OR efficiency.

Simple

Streamlined and efficient



Streamlined instrumentation and fewer trays can help lower sterilization costs and create a system more suitable for today's healthcare environment.

New instruments with the 115mm conical stem are compatible with all current size offerings with only 4 core trays.

10mm Starter Reamer



Clear-Out Reamer



Distal Reamers



Distal Stem Trials (115mm)



Modular Proximal Body Impactor

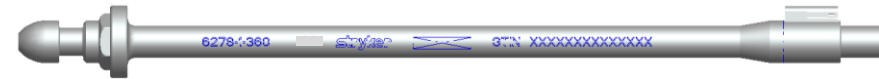

Distal Stem Impactor / Reaming Post



Modular Steady Handle/Head Impactor



Conical Distal Stem Trial Impactor



References



1. Stryker R&D Test Reprt MT05049. Restoration Modular - Median Fatigue Strength Determination of Un-Shot Peened Distal Stem Trunnions. 2005.
2. Stryker R&D Test Report MT03051. Restoration Modular Taper Junction Testing (3 Stage Process). 2003
3. Davy DT, Kotzar GM, Brown RH, et al. Telemetric Force Measurements across the Hip after Total Arthroplasty. J Bone Joint Surg Am. 1988 January 70(1): 45-50.
4. Bergmann G, Graichen F, Rohlmann A. Is Staircase Walking a Risk for the Fixation of Hip Implants? J. Biomechanics. 1995; Vol. 28, No. 5: 535-553.
5. Stryker R&D Test Report MT02094 . Disassembly of Contaminated Ti-6Al-4V ELI Taper Specimens by an Applied Torsion. 2002.
6. Data on file. Stryker internal sales. June 7, 2022.
7. Data on file. Stryker QMS reports. February 3, 2022.
8. El Ashmawy, AA., Hosny, H.A.H., El-Bakoury, A. et al. Mid- to long-term results of the Cone-Conical modular system in revision hip arthroplasty. International Orthopaedics (SICOT) 46, 531–539 (2022). <https://doi.org/10.1007/s00264-021-05237-5>
9. Desai RR, Malkani AL, Hitt KD, Jaffe FF, Schurman JR 2nd, Shen J. Revision total hip arthroplasty using a modular femoral implant in Paprosky type III and IV femoral bone loss. J Arthroplasty. 2012 Sep;27(8):1492-1498.e1. doi: 10.1016/j.arth.2012.03.039. Epub 2012 Jun 27.
10. Marfo KA, Berend KR, Morris MJ, Adams JB, Lombardi AV Jr. Mid-Term Results of Modular Tapered Femoral Stems in Revision Total Hip Arthroplasty. Surg Technol Int. 2019 Nov 10;35:295-300.
11. Goldberg G, Hozack WJ. Modular Stems for Revision of Periprosthetic Hip Fractures: Indications and Technique. Seminars in Arthroplasty 2006; 17:15-17.
12. Patel PO, Klika AK, Murray TG, Elsharkawy KA, Krebs VE, Barsoum WK. Influence of Technique With distally fixed Modular Stems in Revision Total Hip.
13. Hozack, W, Restrepo, C, Parvizi, J, et al. Modular Femoral Stems for Revision Total Hip Arthroplasty. Clin Orthop Relat Res (2011) 469:4 76-482.
14. Niyati Dave, Peter Tulkis, Westrich Geoffrey,MD,Ahmad Faizan. An Anthropometric Analysis Of Key Bone Morphological Parameters For A New Short Conical Stem Design. Orthopaedic Research Society 2022
15. Stryker R&D Technical Report: Characterizing the Physical Properties of the Trident II Tritanium Acetabular Shell. May 22, 2017. A002172226.
16. Stryker R&D Technical Report: Evaluation of the Coefficient of Friction of the Trident II Tritanium Surface. Sep 01, 2016. A001575127.
17. Stryker R&D Technical Memo: Trident II Tritanium Acetabular Shell Coefficient of Friction Equivalence Rationale. Oct 24, 2017. A0026809

A surgeon must always rely on his or her own professional clinical judgment when deciding whether to use a particular product when treating a particular patient. Stryker does not dispense medical advice and recommends that surgeons be trained in the use of any particular product before using it in surgery.

The information presented is intended to demonstrate the breadth of Stryker's product offerings. A surgeon must always refer to the package insert, product label and/or instructions for use before using any of Stryker's products. Products may not be available in all markets because product availability is subject to the regulatory and/or medical practices in individual markets. Please contact your sales representative if you have questions about the availability of products in your area.

Stryker or its affiliated entities own, use, or have applied for the following trademarks or service marks: Restoration, Stryker, Trident, Tritanium. All other trademarks are trademarks of their respective owners or holders. The absence of a product, feature, or service name, or logo from this list does not constitute a waiver of Stryker's trademark or other intellectual property rights concerning that name or logo.