

**stryker**

**LPT<sup>®</sup> 2**

Great Toe Implant

**Operative technique**



**Precise, cannulated instrumentation**

# LPT® 2

## Great Toe Implant

### Table of contents

<b>Product information</b>	<b>3</b>
Implant specification	4
<b>Preoperative planning</b>	<b>5</b>
<b>Operative technique</b>	<b>6</b>
Incision and exposure	6
Base resection	7
Sizing and k-wire placement	8
Reaming	8
Broaching	8
Trial	9
Implant placement	10
Closure	10
Angled LPT Great Toe Implant	11
<b>Ordering information</b>	<b>12</b>

---

Proper surgical procedures and techniques are the responsibility of the medical professional. The following guidelines are furnished for information purposes only. Each surgeon must evaluate the appropriateness of the procedures based on his or her personal medical training and experience. Prior to use of the system, the surgeon should refer to the product package insert for complete warnings, precautions, indications, contraindications and adverse effects. Package inserts are also available by contacting the manufacturer. Contact information can be found on the back of this operative technique and the package insert is available on the website listed.

**As described by Lowell Scott Weil, Sr, DPM, FACFAS**

# Product information

## Design features

- A. Bone conserving, thin profile (page 8)
- B. Cruciate stabilizing stem
- C. Soft tissue securing suture holes
- D. Biocompatible titanium implants (ASTM F67 Grade 4)
- E. Deep dish articulation

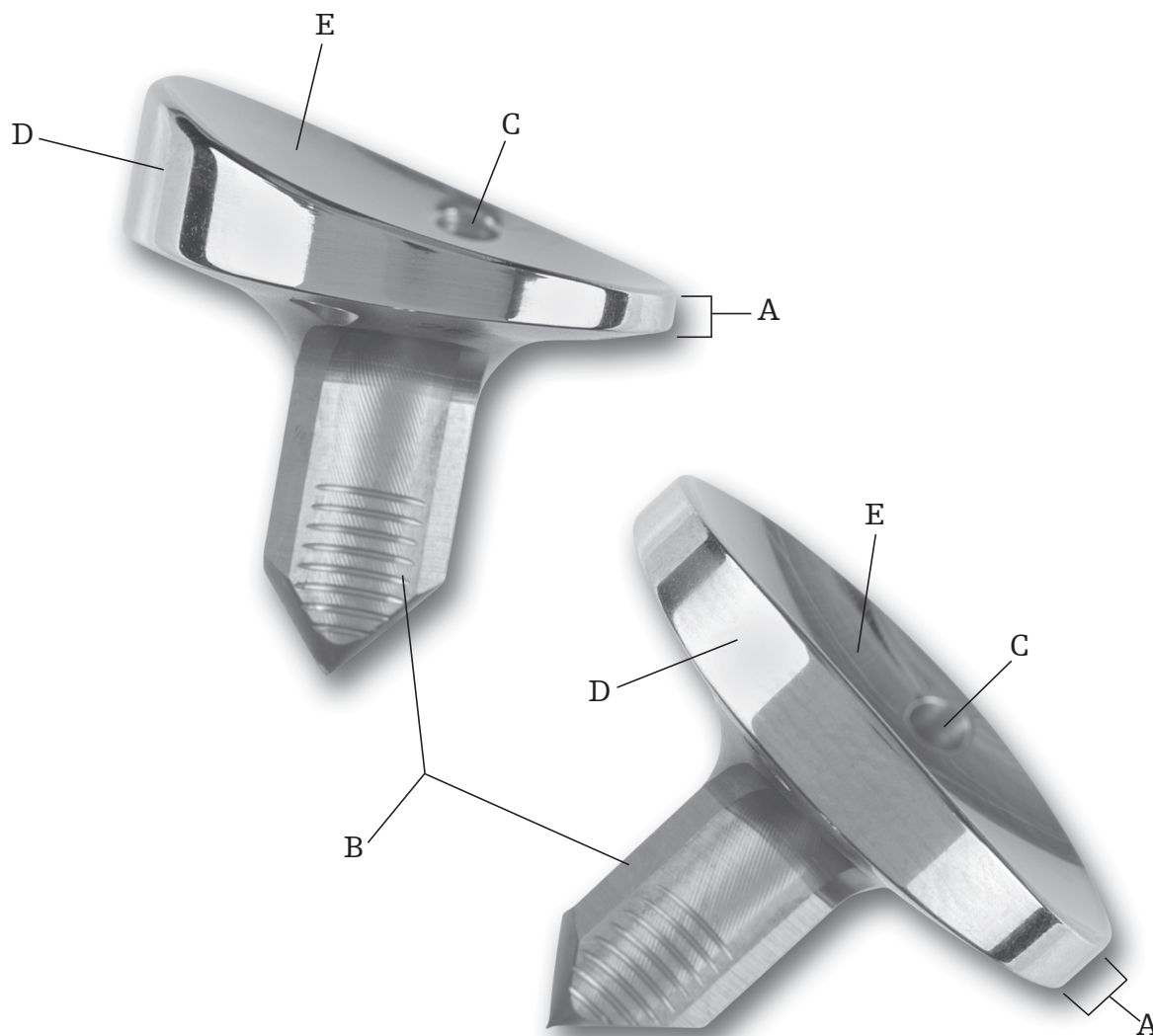

# Product information (cont.)

## Implant specifications

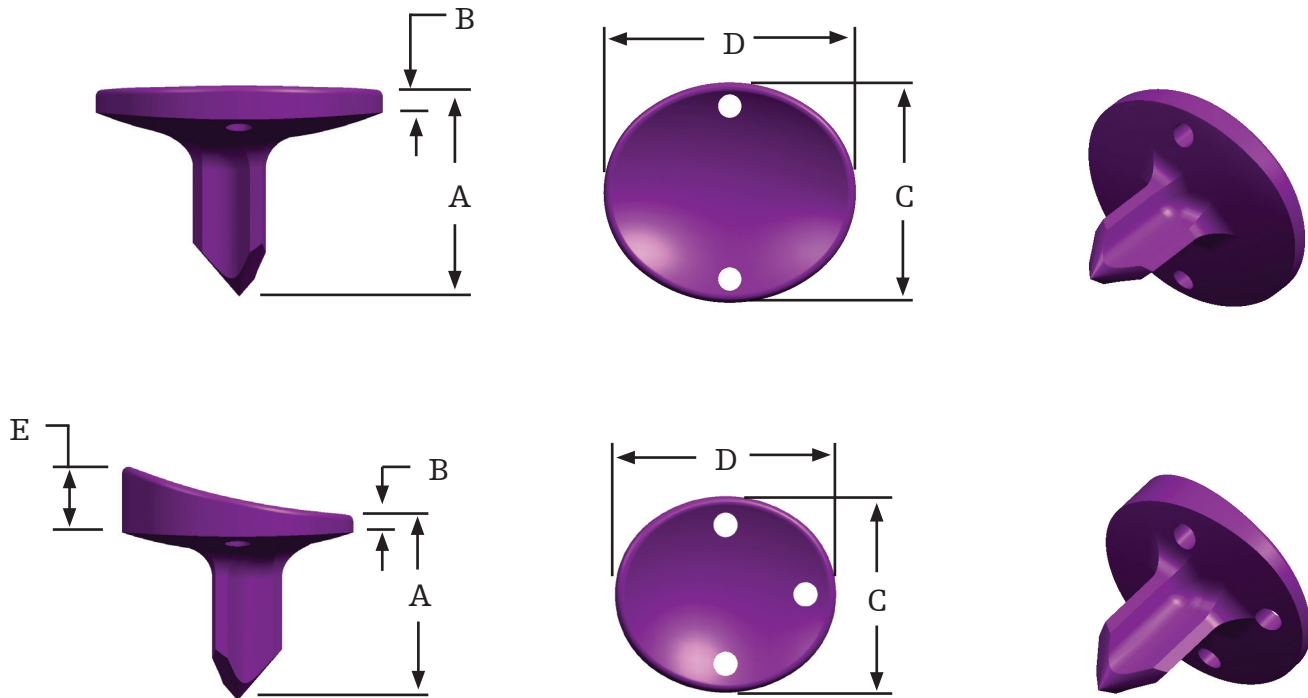

### Dimensional chart

Size	0	1	2	3	1A	2A
A	15mm	15mm	15mm	15mm	14mm	14mm
B	2.4mm	2.4mm	2.0mm	1.7mm	1.3mm	1.4mm
C	15mm	16mm	17mm	18mm	15mm	16mm
D	17mm	19mm	20mm	21mm	16mm	18mm
E	N/A	N/A	N/A	N/A	5mm	5mm

# Preoperative planning

Any great toe joint implant arthroplasty requires consideration of the following general requirements:

- Good neurovascular status
- Adequate skin mobility and coverage
- Functional great toe flexor power
- Adequate bone stock to receive implant

Informed consent that revision or arthrodesis may be necessary.

## Indications

Use of the titanium LPT Great Toe Implant may be considered for cases of first metatarsophalangeal joint degenerative arthritis in the presence of good bone stock, integrity of the metatarsal head and the following clinical conditions:

- Hallux valgus: mild to moderate only (for larger inter-metatarsal angles, an adjunctive metatarsal osteotomy should be considered)
- Painful hallux rigidus, stage 2 and 3
- Revision bunionectomy for arthrofibrotic or painful hallux limitus
- When an alternative to first MTP arthrodesis is considered
- Good condition of the patient
- Good neurovascular status
- Adequate skin mobility and coverage
- Functional great toe flexor power

## Angled great toe is also indicated for:

increased proximal articular set angle (PASA) on the metatarsal head in combination with the above-mentioned indications.

## Contraindications

- Rheumatoid arthritis
- Non-reduced, high, inter-metatarsal angles
- Unreduced cavus foot deformity
- Absence of both sesamoids
- Absence of great toe flexor power

## Operative technique

### Incision and exposure

A 5cm dorsal medial incision is made just medial to the extensor hallucis tendon. Appropriate dissection is used to expose the joint capsule. Careful preservation of the superficial vessels and nerves is undertaken. The skin is retracted and an incision is made to the bone, in line with the skin incision.



Figure 1

The capsular tissues are carefully dissected from the base of the proximal phalanx and first metatarsal head, on the medial, dorsal, and anterolateral aspect. Often, there is a loose bone fragment attached to the phalangeal base and this is excised. Osteophytic lipping surrounding the first metatarsal is removed and the dorsal surface of the first metatarsal head is remodeled so that the dorsal one-fourth of the head is resected. The tissue on the base of the proximal phalanx is also dissected free from all attached areas on the base of the great toe.



Figure 2

## Step 1: Base resection

Using a bone clamp or large towel clamp, the base is elevated. 2mm-6mm of bone is resected from the base of the proximal phalanx. The amount of bone resected will vary by patient, but joint decompression must be considered when making this determination. The base resection is carried out perpendicular to the long axis of the toe, not the proximal phalanx. In this manner, DASA (distal articular set angle) may be corrected concurrently.

### NOTICE

During base resection, remove more bone plantarly than dorsally to allow for ideal saggital plane position.

The sesamoids are inspected and any fibrosis of the sesamoids to the undersurface of the first metatarsal head is freed. The fibular sesamoid is removed when indicated.

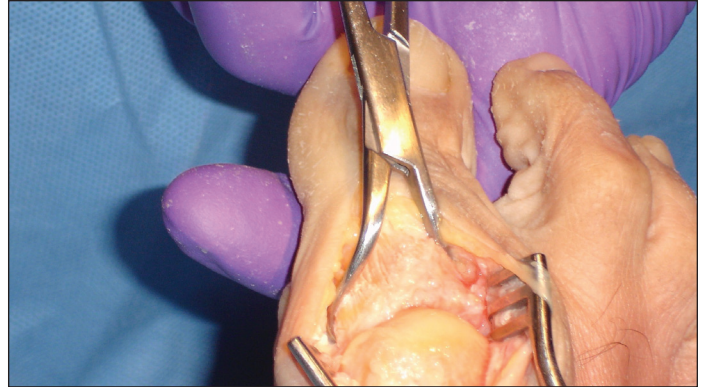

Figure 3

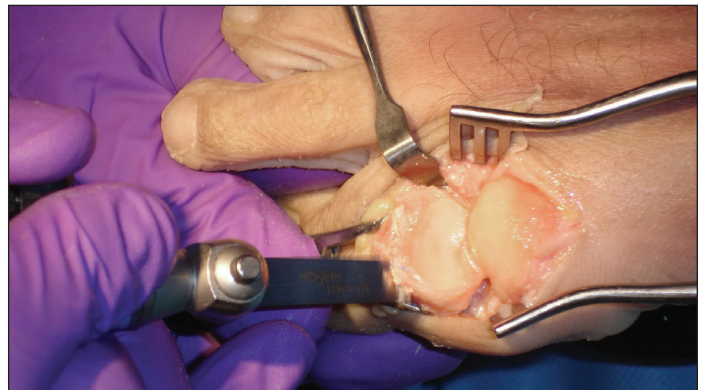

Figure 4

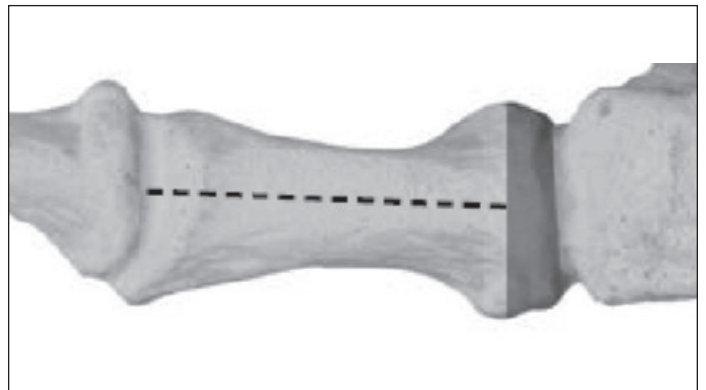

Figure 5

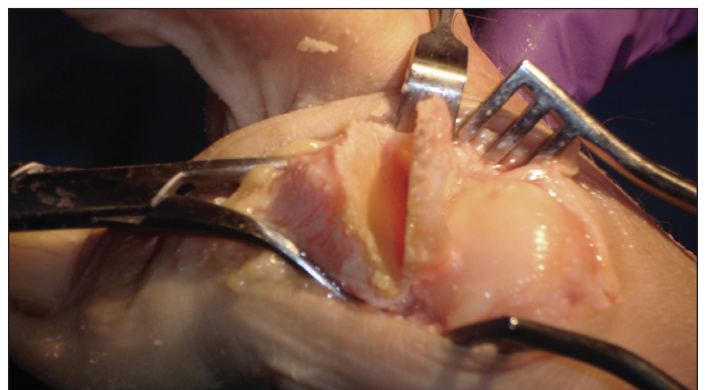

Figure 6

## Step 2: Sizing and k-wire placement

Plantar flex the proximal phalanx until the resected base is 90° to the metatarsal head. Drive the 1.4mm k-wire in the center of the phalanx. Select a sizer that most closely matches the base of the phalanx, and slide the centered hole over the 1.4mm k-wire. Verify that the selected sizer is 1mm-1.5mm smaller than the profile of the phalanx base. Remove sizer from the bone.

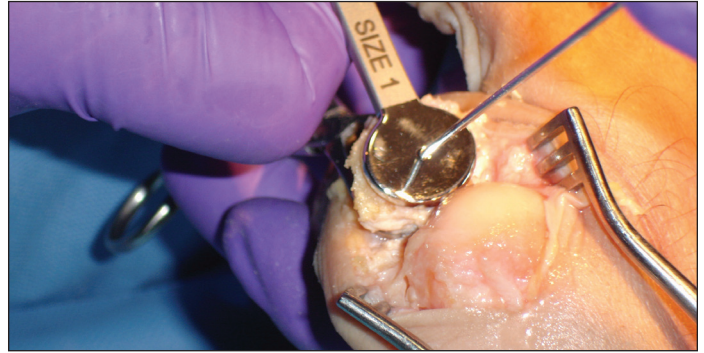

Figure 7

## Step 3: Reaming

Select the reamer that corresponds to the previously selected sizer.

Sizer	Reamer
Size 0/1A	Small
Size 1/2A	Small
Size 2	Medium
Size 3	Large

Place the selected reamer over the 1.4mm k-wire, and ream on power or by hand until the profile of the proximal phalanx matches the base LPT trial.

Use caution when reaming on power as to not over ream the base of the proximal phalanx.

### NOTICE

Use an up-and-down motion while reaming for better control and efficiency.

Remove the reamer from the k-wire. **Do not** remove the k-wire from the phalanx.

## Step 4: Broaching

Place the LPT broach over the 1.4mm k-wire. Care is taken to ensure that the marking facing dorsally on the neck of the instrument matches the correct toe.

Use a small mallet to impact the broach into the center of the proximal phalanx. Continue this until the base of the broach is seated on the bone. Remove the LPT broach by using a reverse motion with the slap hammer.

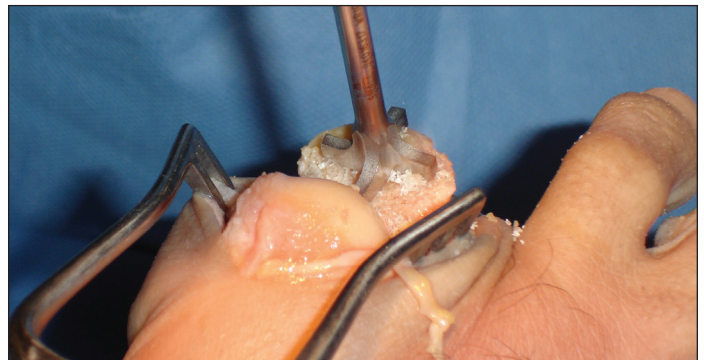

Figure 8



Figure 9



## Step 5: Trial

Select an implant trial that corresponds to the size previously selected, and place the trial stem in the broached hole. Ensure the marking on the dorsal side of the trial corresponds to the correct toe.

Sizer	Trial	Implant
Size 0/1A	0 or 1A	0 or 1A
Size 1/2A	1 or 2A	1 or 2A
Size 2	2	2
Size 3	3	3

Use a small mallet and the implant impactor to seat the trial into the base of the proximal phalanx.

With the trial in place, remove excess bone and osteophytes with a bone rongeur.

Reduce the joint and flex the phalanx dorsally and plantarly, checking for range of motion.

If range of motion and overall fit of the trial is satisfactory, choose an implant that corresponds to the trial being used.

Remove the trial from the bone.

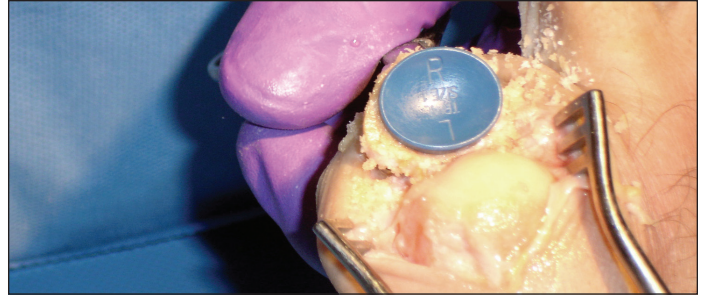

Figure 10

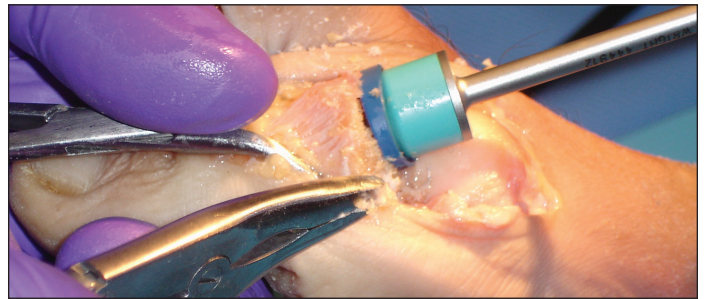

Figure 11

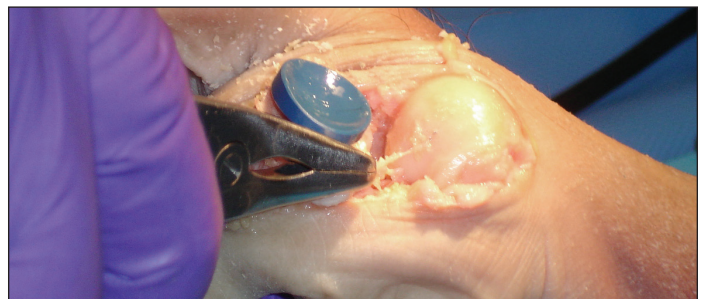

Figure 12

### Optional suture procedure

Make certain that the selected implant is held in the proper alignment so that the stem fits the broached hole. **Do not insert the implant until the plantar suture is placed.** Holding the great toe in distal traction, pass a suture through the intersesamoidal ligament, catching the flexor hallucis longus tendon and then through the hole on the plantar surface of the implant. Repeat this maneuver again to create a pulley type suture.

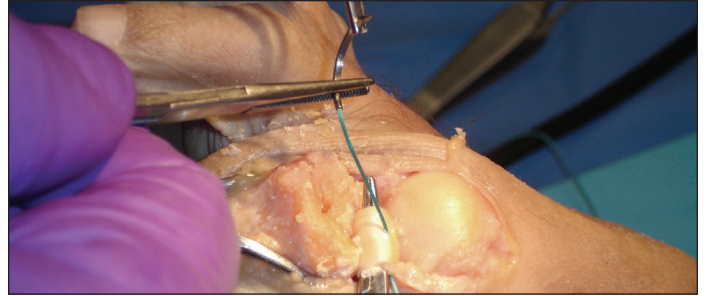

Figure 13

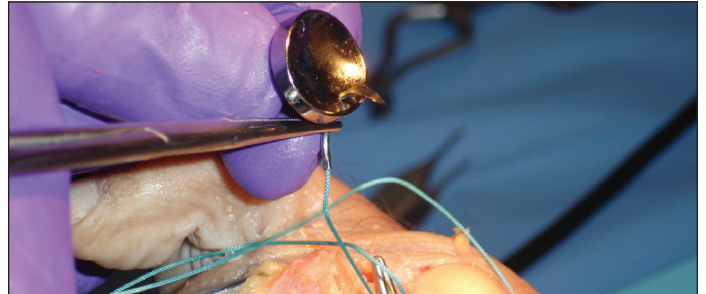

Figure 14

Place the implant into the proximal phalanx and tamp firmly with the implant impactor and a small mallet. Relocate the toe anatomically with the suture ends between the implant and the first metatarsal head. Carefully pull the ends of the suture in opposite directions (medial and lateral) to tighten the pulley suture while holding the toe in ten degrees of plantar flexion.

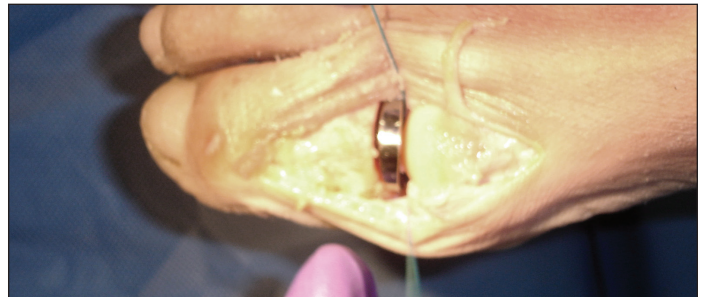

Figure 15

Tie the suture so that the knot falls plantar to the joint. Place the toe through a range of motion to ensure unencumbered movement.

### Step 6: Implant placement

The implant is inserted and tamped into place using the implant impactor.

The great toe is then put through a full range of motion and any impingements are resolved at this time.

### Step 7: Closure

The wound is irrigated and closed in layers and a bulky compression dressing is applied.

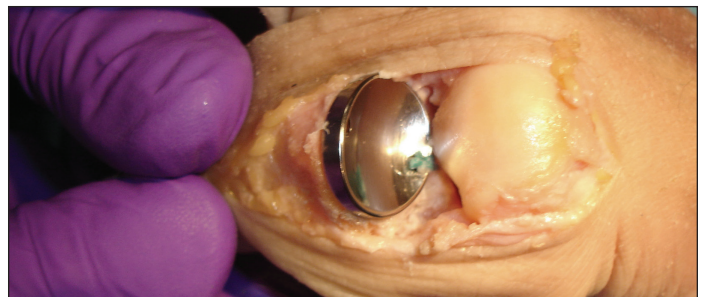

Figure 16

## Angled LPT Great Toe Implant

The Angled LPT Great Toe Implant is used to accommodate an increased PASA (proximal articular set angle) or DMAA (distal metatarsal articular angle) deformity of the articular cartilage of the first metatarsal. The wider portion of the implant is always placed laterally. The technique of the Angled LPT Great Toe is essentially the same as that of the Regular LPT Great Toe Implant with the following addition: a medial perforation hole has been placed in the Angled LPT Toe Implant. During capsular closure, the surgeon may select to place an absorbable suture in the medial aspect of the implant to protect against lateral subluxation during the early healing process.



Figure 17

## Ordering information

### LPT Great Toe Implant

Catalog number	Description
487S000	LPT Regular Great Toe Implant size 0
487S001	LPT Regular Great Toe Implant size 1
487S002	LPT Regular Great Toe Implant size 2
487S003	LPT Regular Great Toe Implant size 3
487A001	LPT Angled Great Toe Implant size 1
487A002	LPT Angled Great Toe Implant size 2



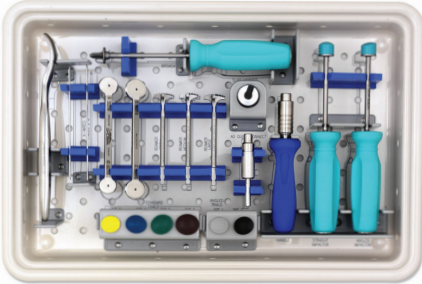

### LPT Great Toe Cannulated Instrument Kit

Part number	Qty.	Description
24872001	1	LPT Great Toe Sizer size 0-1
24872002	1	LPT Great Toe Sizer size 2-3
24872020	1	LPT Great Toe Reamer small
24872003	1	LPT Great Toe Reamer medium
24872004	1	LPT Great Toe Reamer large
24872005	1	LPT Great Toe Broach
24872006	1	LPT Great Toe Impactor straight
24872007	1	LPT Great Toe Impactor angled
24872008	1	LPT Great Toe Elevator
24872009	1	LPT Great Toe Slaphammer
24872010	1	LPT Great Toe Trial size 0
24872011	1	LPT Great Toe Trial size 1
24872012	1	LPT Great Toe Trial size 2
24872013	1	LPT Great Toe Trial size 3
24872014	1	LPT Great Toe Angled Trial size 1A
24872015	1	LPT Great Toe Angled Trial size 2A
24872016	1	LPT Great Toe Tray Base
441112017	1	AO quick connect cannulated
44112009	1	AO cannulated driver handle
24872018	4	1.4mm k.wire

# Notes

---

---

---

---

---

---

---

---

---

---

---

---

---

---

---

---

---

---

---

---

---

---

---

---

---

# Notes

---

---

---

---

---

---

---

---

---

---

---

---

---

---

---

---

---

---

---

---

---

---

---

---

---

## Foot & Ankle

This document is intended solely for the use of healthcare professionals. A surgeon must always rely on his or her own professional clinical judgment when deciding whether to use a particular product when treating a particular patient. Stryker does not dispense medical advice and recommends that surgeons be trained in the use of any particular product before using it in surgery.

The information presented is intended to demonstrate a Stryker product. A surgeon must always refer to the package insert, product label and/or instructions for use, including the instructions for cleaning and sterilization (if applicable), before using any Stryker product. Products may not be available in all markets because product availability is subject to the regulatory and/or medical practices in individual markets. Please contact your Stryker representative if you have questions about the availability of Stryker products in your area.

Stryker Corporation or its divisions or other corporate affiliated entities own, use or have applied for the following trademarks or service marks: LPT, Stryker. All other trademarks are trademarks of their respective owners or holders.

013276A\_27-Oct-2015  
Copyright © 2022 Stryker



**Manufacturer:**  
Stryker Corporation  
1023 Cherry Road  
Memphis, TN 38117  
800 238 7117  
901 867 9971  
[stryker.com](http://stryker.com)